SANITARY SEWERS**PART 1 - GENERAL****1.01 SECTION INCLUDES**

- A. Sanitary Sewer Gravity Mains
- B. Sanitary Sewer Force Mains
- C. Sanitary Sewer Services

1.02 DESCRIPTION OF WORK

- A. Construct sanitary sewer gravity and force mains.
- B. Construct or relocate building sanitary sewer services, stubs, and connections.

1.03 SUBMITTALS

Comply with Division 1 - General Provisions and Covenants.

1.04 SUBSTITUTIONS

Comply with Division 1 - General Provisions and Covenants.

1.05 DELIVERY, STORAGE, AND HANDLING

Comply with Division 1 - General Provisions and Covenants.

1.06 SCHEDULING AND CONFLICTS

Comply with Division 1 - General Provisions and Covenants.

1.07 SPECIAL REQUIREMENTS

None.

1.08 MEASUREMENT AND PAYMENT**A. Sanitary Sewer Gravity Main:****1. Trenched:**

- a. **Measurement:** Each type and size of pipe installed in a trench will be measured in linear feet along the centerline of the pipe from center of manhole to center of manhole.
- b. **Payment:** Payment will be made at the unit price per linear foot for each type and size of pipe.
- c. **Includes:** Unit price includes, but is not limited to, trench excavation; dewatering; furnishing and installing pipe; pipe lining (if specified); furnishing, placing, and compacting bedding and backfill material; wyes and other fittings; pipe joints; pipe connections; testing; and inspection.

2. Trenchless:

- a. **Measurement:** Each type and size of pipe installed by trenchless methods will be measured in linear feet along the centerline of pipe.
- b. **Payment:** Payment will be made at the unit price per linear foot for each type and size of pipe.
- c. **Includes:** Unit price includes, but is not limited to, furnishing and installing pipe; pipe lining (if specified); trenchless installation materials and equipment; pit excavation; dewatering; placing and compacting backfill material; pipe connections; testing; and inspection.

1.08 MEASUREMENT AND PAYMENT (Continued)**B. Sanitary Sewer Gravity Main with Casing Pipe:****1. Trenched:**

- a. Measurement:** Each type and size of pipe installed with a casing pipe in a trench will be measured in linear feet along the centerline of the casing pipe, from end of casing to end of casing.
- b. Payment:** Payment will be made at the unit price per linear foot for each type and size of carrier pipe.
- c. Includes:** Unit price includes, but is not limited to, furnishing and installing both carrier pipe and casing pipe; pipe lining (if specified); trench excavation; dewatering; furnishing, placing, and compacting bedding and backfill material; furnishing and installing annular space fill material; casing spacers; pipe connections; testing; and inspection.

2. Trenchless:

- a. Measurement:** Each type and size of pipe installed by trenchless methods with a casing pipe will be measured in linear feet along the centerline of the casing pipe from end of casing to end of casing.
- b. Payment:** Payment will be made at the unit price per linear foot for each type and size of carrier pipe.
- c. Includes:** Unit price includes, but is not limited to, furnishing and installing both carrier pipe and casing pipe; pipe lining (if specified); trenchless installation materials and equipment; pit excavation; dewatering; and placing and compacting backfill material; casing spacers; furnishing and installing annular space fill material; pipe connections; testing; and inspection.

C. Sanitary Sewer Force Main:**1. Trenched:**

- a. Measurement:** Each type and size of pipe installed in an open trench will be measured in linear feet along the centerline of the pipe from the outside wall of the pumping station to the center of manhole, or from the center of manhole to the center of manhole.
- b. Payment:** Payment will be made at the unit price per linear foot for each type and size of pipe.
- c. Includes:** Unit price includes, but is not limited to, trench excavation; dewatering; furnishing and installing pipe; furnishing, placing, and compacting bedding and backfill; wyes and other fittings; pipe joints; testing; and inspection.

2. Trenchless:

- a. Measurement:** Each type and size of pipe installed by trenchless methods will be measured in linear feet along the centerline of the pipe.
- b. Payment:** Payment will be made at the unit price per linear foot for each type and size of pipe.
- c. Includes:** Unit price includes, but is not limited to, furnishing and installing pipe; trenchless installation materials and equipment; pit excavation; dewatering; placing and compacting backfill material; pipe connections; testing; and inspection.

D. Sanitary Sewer Force Main with Casing Pipe:**1. Trenched:**

- a. Measurement:** Each type and size of pipe installed with a casing pipe in a trench will be measured in linear feet along the centerline of the casing pipe.
- b. Payment:** Payment will be made at the unit price per linear foot for each type and size of pipe.

1.08 MEASUREMENT AND PAYMENT (Continued)

- c. Includes:** Unit price includes, but is not limited to, furnishing and installing both carrier pipe and casing pipe; trench excavation; dewatering; furnishing, placing, and compacting bedding and backfill material; furnishing and installing annular space fill material; casing spacers; pipe connections; testing; and inspection.
- 2. Trenchless:**

 - a. Measurement:** Each type and size of pipe installed by trenchless methods with a casing pipe will be measured in linear feet along the centerline of the casing pipe.
 - b. Payment:** Payment will be made at the unit price per linear foot for each type and size of carrier pipe.
 - c. Includes:** Unit price includes, but is not limited to, furnishing and installing both carrier pipe and casing pipe; trenchless installation materials and equipment; pit excavation; dewatering; placing and compacting backfill material; casing spacers; furnishing and installing annular space fill material; pipe connections; testing; and inspection.
- E. Sanitary Sewer Service Stub:** The portion of the sanitary sewer service from the main to a point 10 feet outside of the right-of-way line or as specified in the contract documents (comply with [Figure 4010.201](#)).

 - 1. Measurement:** Each type and size of pipe will be measured in linear feet along the centerline of the pipe from the end of the pipe to the centerline of the sewer main.
 - 2. Payment:** Payment will be made at the unit price per linear foot for each type and size of sanitary sewer service stub.
 - 3. Includes:** Unit price includes, but is not limited to, trench excavation; furnishing and installing pipe; furnishing, placing, and compacting bedding and backfill material; tap; fittings; testing; and inspection.
- F. Sanitary Sewer Service Relocation:** The portion of an existing sanitary sewer service in a zone of conflict.

 - 1. Measurement:** Each completed relocation will be counted.
 - 2. Payment:** Payment will be made at the unit price for each relocation.
 - 3. Includes:** Unit price includes, but is not limited to, removal of existing pipe, trench excavation, furnishing new pipe and bedding material, placing and compacting bedding and backfill material, connection back to existing service, compaction, testing, and inspection.
- G. Sewage Air Release Valve and Pit:**

 - 1. Measurement:** Each completed installation, including valve, accessories, and pit, will be counted.
 - 2. Payment:** Payment will be made at the unit price for each sewage air release valve and pit.
 - 3. Includes:** Unit price includes, but is not limited to, excavation; furnishing, placing, and compacting bedding and backfill material; and testing.

1.08 MEASUREMENT AND PAYMENT (Continued)**H. Removal of Sanitary Sewer:**

1. **Measurement:** Each type and size of pipe removed will be measured in linear feet from end to end.
2. **Payment:** Payment will be at the unit price per linear foot for each type and size of pipe.
3. **Includes:** Unit price includes, but is not limited to, removal, disposal, and capping (if specified) of pipe; and furnishing, placing, and compacting backfill material.

I. Sanitary Sewer Cleanout:

1. **Measurement:** Each sanitary sewer cleanout will be counted.
2. **Payment:** Payment will be made at the unit price for each cleanout.
3. **Includes:** Unit price includes, but is not limited to, plug at the end of the main, fittings, riser pipe, cap with screw plug, casting, and concrete casting encasement.

J. Connection to Existing Manhole: Comply with [Section 6010, 1.08, G.](#)**K. Sanitary Sewer Abandonment, Plug:**

1. **Measurement:** Each plug will be counted.
2. **Payment:** Payment will be made at the unit price for each plug installed.
3. **Includes:** Unit price includes, but is not limited to, trench excavation (if necessary), cutting pipe (if required), furnishing and placing plug materials, and placing and compacting backfill material.

L. Sanitary Sewer Abandonment, Fill and Plug:

1. **Measurement:** Each size of sanitary sewer to be abandoned by filling and plugging will be measured in linear feet.
2. **Payment:** Payment will be at the unit price per linear foot for each size of pipe filled and plugged.
3. **Includes:** Unit price includes but is not limited to, trench excavation (if necessary), cutting pipe (if required), furnishing and placing pipe fill material, furnishing and placing plug materials, and placing and compacting backfill material.

PART 2 - PRODUCTS**2.01 SANITARY SEWER (Gravity Mains)****A. Solid Wall Polyvinyl Chloride Pipe (PVC) 8 inch to 15 inch:**

1. Comply with ASTM D 3034, SDR 26, unless SDR 35 is specified.
2. Pipe stiffness per ASTM D 2412.
 - a. SDR 26: Minimum pipe stiffness of 115 psi.
 - b. SDR 35: Minimum pipe stiffness of 46 psi.
3. PVC plastic meeting ASTM D 1784, Cell Classification 12454 or 12364.
4. Integral bell and spigot joints with elastomeric seals complying with ASTM D 3212 and ASTM F 477.

B. Solid Wall Polyvinyl Chloride Pipe (PVC) 18 inch to 27 inch:

1. Comply with ASTM F 679.
2. Pipe stiffness per ASTM D 2412, 46 psi.
3. PVC plastic meeting ASTM D 1784, Cell Classification 12454 or 12364.
4. Integral bell and spigot joints with elastomeric seals complying with ASTM D 3212 and ASTM F 477.

C. Corrugated Polyvinyl Chloride Pipe (PVC) 8 inch to 36 inch:

1. Comply with ASTM F 949, smooth interior, corrugated exterior.
2. Pipe stiffness per ASTM D 2412.
 - a. 8 inch to 10 inch: Minimum pipe stiffness of 115 psi, unless 46 psi is specified.
 - b. 12 inch to 36 inch: Minimum pipe stiffness of 46 psi.
3. PVC resin meeting ASTM D 1784, Cell Classification 12454.
4. Integral bell and spigot joints with elastomeric seals complying with ASTM D 3212 and ASTM F 477.

D. Closed Profile Polyvinyl Chloride Pipe (PVC) 21 inch to 36 inch:

1. Comply with ASTM F 1803.
2. Pipe stiffness per ASTM D 2412, 46 psi.
3. PVC plastic meeting ASTM D 1784, Cell Classification 12364.
4. Integral bell and spigot joints with elastomeric seals complying with ASTM D 3212 and ASTM F 477.

2.01 SANITARY SEWER (Gravity Mains) (Continued)**E. Polyvinyl Chloride Composite Pipe (truss type PVC) 8 inch to 15 inch:**

1. Comply with ASTM D 2680. Pipe constructed with truss-type structure between inner and outer PVC walls with voids filled with lightweight concrete.
2. Pipe stiffness per ASTM D 2412, 200 psi.
3. PVC plastic meeting ASTM D 1784, Cell Classification 12454.
4. Integral bell and spigot joints with elastomeric seals complying with ASTM D 3212 and F 477.

F. Reinforced Concrete Pipe (RCP) 18 inch to 144 inch:**1. General:**

- a. Comply with ASTM C 76 (AASHTO M 170).
- b. Minimum Class IV (3000D), Wall B.
- c. Tongue and groove joints.
- d. Rubber O-ring or profile gasket flexible joint complying with ASTM C 443.

2. Pipe Lining:

- a. Epoxy Coal Tar:
 - 1) Coat interior pipe barrel and all joint surfaces with two-component coal-tar epoxy-polyamide black paint or approved equal.
 - 2) Lining Material: Steel Structures Painting Council (SSPC) Specification No. 16, Table 1.
 - a) Minimum epoxy resin content 34% to 35% by dry film weight.
 - b) Minimum sag resistance 40 mils.
 - c) Minimum solids 80% by volume.
 - 3) Apply according to lining material manufacturer's recommendations.
- b. PVC:
 - 1) Minimum thickness of 0.65 inch.
 - 2) Locking extensions extruded from the same material as the liner a minimum of 0.375 inches tall spaced a maximum of 2.5 inches.
 - 3) Liner to cover the entire interior of the concrete pipe.
 - 4) Minimum tensile strength of liner is 2200 psi with a minimum elongation of 200% at breaking.
 - 5) Meet EPA 9090 for chemical resistance.
 - 6) Free of cracks, cleavages, pinholes, or other defects.
 - 7) Joint sealer strip to be from the same material as the liner.
- c. HDPE:
 - 1) Minimum thickness of 0.064 inches according to ASTM D5199.
 - 2) Minimum density of 0.90 g/cm³.
 - 3) Meet EPA 9090 for chemical resistance.
 - 4) Locking extensions made from the same material as the liner with minimum pullout strength of 14,000 pounds per square foot.
 - 5) Free of cracks, cleavages, pinholes, or other defects.
 - 6) Joint sealer strip to be from the same material as the liner.
 - 7) If gasketed joints, comply with ASTM F 477 and ability to withstand a minimum groundwater pressure equal to that of the pipe liner or 20 psi, whichever is greater.

G. Ductile Iron Pipe (DIP) 8 inch to 54 inch:**1. General:**

- a. Comply with AWWA C151.
- b. Minimum thickness Class 52.

2.01 SANITARY SEWER (Gravity Mains) (Continued)**2. Interior Linings:**

- a. Provide interior lining for ductile iron pipe and fittings used for all gravity sewers and drop connections.
- b. Use linings specifically designed for sanitary sewer applications, such as ceramic epoxy. Other lining types may be allowed upon approval of the Engineer.
- c. Apply lining to interior of unlined ductile iron pipe and fittings according to the published specifications from the manufacturer.
- d. Seal all cut ends and repair field damaged areas according to the manufacturer's recommendations.

3. Exterior Coating: Asphalt.**4. Joints:** Push-on complying with AWWA C111.**5. Fittings:** Mechanical complying with AWWA C110 or AWWA C153.**6. Polyethylene Encasement:**

- a. Comply with AWWA C105.
- b. Minimum thickness of 8 mils.
- c. Use for all ductile iron pipe and fittings in buried service.

H. Vitrified Clay Pipe (VCP) 8 inch to 42 inch:

1. Pipe and fittings complying with ASTM C 700.
2. Compression joints complying with ASTM C 425 for plain end pipe or bell and spigot pipe.
3. Test according to ASTM C 301.

I. Double Walled Polypropylene Pipe 12 inch to 30 inch:

1. Comply with ASTM F 2764.
2. Minimum pipe stiffness per ASTM D 2412, 46 psi.
3. Integral bell and spigot joint complying with ASTM D 3212 and ASTM F 477.

J. Triple Walled Polypropylene Pipe 30 inch to 36 inch:

1. Comply with ASTM F 2764.
2. Minimum pipe stiffness per ASTM D 2412, 46 psi.
3. Integral bell and spigot joint complying with ASTM D 3212 and ASTM F 477.

2.02 SANITARY SEWER FORCE MAINS

A. Ductile Iron Pipe (DIP) 4 inch to 54 inch: Comply with the DIP requirements in Section 4010, 2.01. If joint restraints are specified, comply with [Section 5010, 2.03](#).

B. Polyvinyl Chloride Pipe (PVC): Comply with the requirements in [Section 5010, 2.01](#) for PVC pipe. Provide restrained joints when specified.

C. Fusible PVC and HDPE Pipe: Comply with the requirements in [Section 5011, 2.01](#).

2.02 SANITARY SEWER FORCE MAINS (Continued)**D. Sewage Air Release Valve:**

1. **General:** Consists of an elongated tapered or conical body and a float to operate (open and close) under pressure without spillage. Provide valves suitable for pressures up to 150 psi. Use a float with a linkage connection to the seal plug assembly to prevent irregular air release and protect the connecting rod. Ensure the bottom of the valve body is sloped or funnel-shaped to encourage the accumulated sewage and solids to drain from the valve. Preserve a volume of air at all times between the liquid sewage and the seal plug assembly. Provide a flushing port with attachments for backwashing.
2. **Materials:**
 - a. **Body and Cover:**
 - 1) Stainless Steel: ASTM A 351.
 - 2) Cast Iron: ASTM A 126, Grade B.
 - 3) Ductile Iron: ASTM A 536, Grade 65-45-12.
 - 4) Other corrosion resistant materials.
 - b. **Internal Metal Components:** Stainless steel.
 - c. **Float:** Stainless steel, ASTM A 240, Type 304 or Type 316, or foamed polypropylene.
 - d. **Seal Plug Assembly:** Stainless steel, foamed polypropylene, EPDM rubber, Nitrile (Buna-N) rubber, and reinforced nylon.
3. **Tapping Saddle:** Stainless steel or nylon.
4. **Pit:** Construct according to [Figure 4010.202](#).

E. Tracer Wire: Comply with [Section 5010, 2.05](#). Tracer wire will be required on all force mains.

F. Tracer Wire Station:

1. Two internal terminals with shunt.
2. Five to six foot plastic post (color as specified by the Jurisdiction).
3. Removable top cap with lock.
4. Decals indicating "Sewer Force Main" or similar language.

2.03 CASING PIPE

Comply with [Section 3020, 2.02](#) for casing pipe requirements.

2.04 SANITARY SEWER SERVICES**A. Connection to Main:**

1. **PVC Main:**
 - a. Preformed wye or tee service fitting with integral bell and spigot joints with elastomeric seals complying with ASTM D 3034 or ASTM F 949.
 - b. Preformed saddle wye or saddle tee for service tap complying with ASTM D 3034 or ASTM F 949.
 - c. PVC plastic meeting ASTM D 1784, Cell Classification 12454.

2.04 SANITARY SEWER SERVICES (Continued)

- 2. PVC Composite Main:**
 - a. Preformed wye or tee service fitting with integral bell and spigot joints with elastomeric seals complying with ASTM D 3212.
 - b. Preformed saddle wye or saddle tee for service tap complying with ASTM D 2680.
 - 3. RCP Main:** Preformed saddle wye or saddle tee service tap designed for use with RCP.
 - 4. VCP Main:**
 - a. Precast VCP wye or tee service fitting complying with ASTM C 700 for pipe and ASTM C 425 for compression joints.
 - b. Preformed saddle wye or saddle tee service tap designed for use with VCP.
 - 5. DIP Main:**
 - a. Use DIP wye or tee fittings complying with AWWA C110 or AWWA C153.
 - b. Preformed saddle wye or tee services tap designed for use with DIP. Cut the hole for the tap with equipment designed for application.
- B. Wye and Tee Pipe Stop:** All saddle wye or saddle tee fittings must provide integrally molded pipe stop in the branch for positive protection against service pipe insertion beyond the inside of sewer main pipe wall.
- C. Service Pipe:** Use products as required by local plumbing code or regulations, if applicable. Otherwise, use the following:
- 1. PVC:**
 - a. Comply with ASTM D 3034, minimum thickness SDR 23.5 minimum pipe stiffness of 153 psi as per ASTM D 2412.
 - b. PVC plastic meeting ASTM D 1784, Cell Classification 12454.
 - c. Integral bell and spigot type rubber gasket joint complying with ASTM D 3212.
 - 2. DIP:** As specified for sanitary sewer force main, including polyethylene encasement.
- D. Connection to Existing Service:** Comply with [Section 4050, 2.06](#).

2.05 SANITARY SEWER SERVICE RELOCATIONS

- A. Comply with Section 4010, 2.04 for all materials used for sanitary service relocation.
- B. Use the same nominal size as the existing service being relocated.

2.06 SANITARY SEWER CLEANOUT

Comply with [Figure 4010.203](#).

PART 3 - EXECUTION**3.01 EXAMINATION**

- A. Verify measurements at site. Make necessary field measurements to accurately determine pipe makeup lengths or closures.
- B. Examine site conditions to ensure construction operations do not pose hazards to adjacent structures or facilities.

3.02 GRAVITY SEWER INSTALLATION**A. General:**

- 1. Install watertight plug to prevent water from entering the existing sewer system.
- 2. Clean pipe interior and joints prior to installation. Keep pipe clean during construction.
- 3. Begin at the lowest point in the line. Lay groove or bell end pointing upstream unless otherwise specified.
- 4. Assemble joints according to Section 4010, 3.04.
- 5. Use a saw to cut ends of pipe flush with inside wall of manholes and structures. Do not use hammer or other means to break pipe.
- 6. Provide manholes as specified in the contract documents.
- 7. Install cap, plug, or bulkhead at exposed ends of pipe upon completion of construction or whenever pipe installation is not in progress.

B. Trenched:

- 1. Excavate trench and provide pipe bedding and backfill material as specified in [Section 3010](#).
- 2. Prepare trench bottom to design line and grade so that only minor movement of the pipe is necessary after installation.
- 3. Lay pipe to design line and grade. Set field grades to invert of pipes.
- 4. Provide uniform bearing for full pipe barrel length. Excavate bell holes as necessary for uniform support of pipe barrel on bedding material.
- 5. Do not lay pipe in water or on saturated soil or bedding, or allow water to rise in trench around pipe prior to placing backfill material.
- 6. Do not disturb installed pipe and bedding when using movable trench boxes and shields. Block or anchor pipe as necessary to prevent joint displacement.
- 7. Install wye or tee service fitting at each location specified in the contract documents.

C. Trenchless: Comply with [Section 3020](#).**3.03 SANITARY SEWER INSTALLED WITHIN A CASING PIPE**

Comply with [Section 3020, 3.04](#) for installation of sanitary sewer within casing pipe.

3.04 GRAVITY MAIN PIPE JOINTING**A. General:**

1. Clean joint surfaces to remove soil or foreign material prior to jointing pipe.
2. Assemble joints according to pipe manufacturer's recommendations. Use equipment that does not apply damaging forces to pipe joints.

B. Polyvinyl Chloride Pipe (PVC) and Polyvinyl Chloride Composite Pipe (truss-type):

1. Coat rubber gasket and joint with soap-based lubricant immediately prior to closing joint.
2. Seal ends of PVC composite and closed profile pipe at manholes with the coating recommended by the manufacturer.

C. Reinforced Concrete Pipe (RCP): Coat rubber gasket and joint with soap-based lubricant immediately prior to closing joint.**D. Ductile Iron Pipe (DIP):**

1. Push-on Joint: Coat gasket and joint with soap-based lubricant immediately prior to closing joint.
2. Mechanical Joint: Wash plain end, bell socket, and gasket with soap solution. Press gasket into socket, set gland, and tighten bolts uniformly.

E. Polypropylene Pipe: Coat gasket and bell with lubricant immediately prior to closing joint.**F. Connections between Dissimilar Pipes:**

1. Use manufactured adapters or couplings approved by the Engineer.
2. Where adapters or couplings are not available, the Engineer may authorize use of a Type PC-2 concrete collar as shown on [Figure 4020.211](#).

3.05 FORCE MAIN INSTALLATION**A. General:** Install according to [Section 5010](#).**B. Tracer Wire:**

1. Required for all force main installations. Comply with [Section 5010](#).
2. Install tracer wire station at each end of the force main and at additional locations specified in the contract documents.
3. Bury end of tracer wire station 2 feet and compact.

3.06 SANITARY SEWER SERVICE STUBS**A.** Provide sanitary sewer service stubs at locations specified in the contract documents.**B.** Install wye or tee for each service connection.

1. Connection of sanitary service to new sewer main, except RCP:
 - a. Use only factory wye or tees.
 - b. Install according to manufacturer's requirements and Section 4010, 2.04 and 3.04 for joints.

3.06 SANITARY SEWER SERVICE STUBS (Continued)

2. Connection to existing sewer main and new RCP:
 - a. Cut sewer main for service tap with hole saw or sewer tap drill.
 - b. Use preformed saddle wye or saddle tee for service tap. Use a gasketed saddle with rigid pipe mains and a solvent-cemented saddle with PVC mains.
 - c. Install according to the manufacturer's requirements, but always attach with at least two stainless steel band clamps.
- C. Install service stub from sewer main to a location 10 feet beyond the right-of-way line or as specified in the contract documents. Comply with [Figure 4010.201](#).
 1. Install according to Section 4010, 3.02.
 2. Install service stub with a slope between 2% and 5% for 4 inch pipes, and between 1% and 5% for pipes 6 inches and greater.
 3. Terminate end of service stub 10 to 12 feet below finished ground elevation or as specified in the contract documents.
 4. If the depth of the sewer main causes the service to exceed a depth of 12 feet or a slope of 5%, install a service riser.
 5. For undeveloped properties, place watertight stopper, cap, or plug in end of sanitary sewer service. Mark the end of the service line as required by the Jurisdiction or as specified in the contract documents.
 6. For reconnection of new service pipe with existing service pipe, comply with the Jurisdiction's plumbing code.

3.07 SANITARY SEWER SERVICE RELOCATION

- A. Relocate existing sanitary sewer services that conflict with new storm or sanitary sewer installations. Existing services located within a conflict zone from 6 inches below the bottom of the proposed sewer pipe to 2 inches above the top of the proposed sewer pipe require relocation.
- B. When a conflicting service is encountered:
 1. Determine grades and elevations of the existing service and proposed main.
 2. Determine the extent of service replacement necessary to relocate the service outside of the conflict zone while maintaining a minimum 1% slope on the sewer service.
 3. If it is not feasible to maintain a minimum slope of 1% on the relocated service, a special design and additional work may be required. Stop work and contact the Engineer. Do not remove sewer service unless directed by the Engineer.
 4. If service relocation with a minimum slope of 1% is feasible, proceed with removal and replacement of the existing sanitary sewer service.
 - a. Length of replacement varies. Remove the existing service to the extent necessary to move the service out of the conflict zone.
 - b. Use all new materials complying with Section 4010, 2.04.
 - c. Re-install the service according to Section 4010, 3.02.
 - d. Maintain a minimum 1% grade on relocated service.

3.08 SANITARY SEWER ABANDONMENT**A. Plug:**

1. Prior to placing the sewer plug, the Engineer will verify the sewer line is not in use.
2. Construct sewer plug by completely filling the end of the pipe with concrete. Force concrete into the end of the pipe for a distance of 16 inches, or one-half the pipe diameter, whichever is greater.

B. Fill:

1. Prior to filling the sewer, the Engineer will verify the sewer line is not in use.
2. If specified in the contract documents, fill the line to be abandoned with flowable mortar, foamed cellular concrete, or CLSM (comply with [Section 3010](#)) by gravity flow or pumping.
3. Batching, mixing, and placing may be started when temperature is 34°F and rising. Cease mixing and placing when temperature is 38°F or less and falling.

3.09 CONNECTION TO EXISTING MANHOLE

Comply with [Section 6010, 3.05](#).

3.10 SANITARY SEWER CLEANOUT

Provide cleanouts where specified in the contract documents. Comply with [Figure 4010.203](#).

3.11 TOLERANCES

Apply the following tolerances to utilities installed by open trench construction. For trenchless construction, comply with [Section 3020](#).

A. Gravity Main:

1. Do not allow horizontal and vertical alignment to vary from design line and grade at any structure by more than 1% of the inside diameter of the pipe or 1/4 inch, whichever is larger.
2. Do not allow the horizontal alignment of the pipe to vary from design line at any point along the pipe by more than 1% of the inside diameter of the pipe.
3. Low spots holding water exceeding the following depths for each pipe size will be considered unacceptable and must be removed and reinstalled to proper grade.

Pipe Diameter	Maximum Low Spot Depth
8"	1/2"
10"	1/2"
12"	3/4"
15"	3/4"
18" and Larger	5% of Pipe Diameter*

* Measured to the nearest 1/2"

- B. Force Main:** Do not allow horizontal and vertical alignment of trenched force mains to vary from design line and grade by more than 3 inches.

3.12 CONFLICTS**A. Horizontal Separation of Gravity Sanitary and Combined Sewers from Water Mains:**

Separate gravity sanitary and combined sewer mains from water mains by a horizontal distance of at least 10 feet unless:

1. The top of a sewer main is at least 18 inches below the bottom of the water main, and
2. The sewer is placed in a separate trench or in the same trench on a bench of undisturbed earth at a minimum horizontal separation of 3 feet from the water main.
3. When it is impossible to obtain the required horizontal clearance of 3 feet and a vertical clearance of 18 inches between sewers and water mains, provide a linear separation of at least 2 feet and one of the following:
 - a. Construct sanitary and combined sewers of water main materials meeting the requirements of [Section 5010, 2.01](#).
 - b. Enclose the water main in a watertight casing pipe with an evenly spaced annular gap and watertight end seals.

B. Horizontal Separation of Water Mains from Sanitary and Combined Sewer Manholes:

Ensure water pipes do not pass through or come in contact with any part of a sanitary or combined sewer manhole. Maintain a minimum horizontal separation of 3 feet.

C. Separation of Sanitary Sewer Force Mains from Water Mains: Separate sanitary sewer force mains and water mains by a horizontal distance of at least 10 feet unless:

1. The force main is constructed of water main materials meeting a minimum pressure rating of 150 psi and the requirements of [Section 5010, 2.01](#) and
2. The sewer force main is laid at least 4 linear feet from the water main.

D. Separation of Sanitary and Combined Sewers and Water Main Crossovers:

1. Vertically separate sanitary sewers crossing under any water main by at least 18 inches when measured from the top of the sewer to the bottom of the water main. If physical conditions prohibit the separation, do not place the sewer closer than 6 inches below a water main or 18 inches above a water main. Maintain the maximum feasible separation distance in all cases.
2. Where the sanitary sewer crosses over or is less than 18 inches below a water main, utilize one of the following within 10 feet measured edge-to-edge horizontally, centered on the crossing:
 - a. Construct sewer pipe of water main material.
 - b. Enclose the water main in a watertight casing pipe with an evenly spaced annular gap and watertight end seals.

3.13 CLEANING, INSPECTION, AND TESTING

Clean, inspect, and test sanitary sewer per [Section 4060](#).

END OF SECTION

This page was intentionally left blank

- ① Place bedding and backfill material as required for sewer main.
- ② Service Line Slope:
4 inch: 2% to 5%
6 inch and greater: 1% to 5%

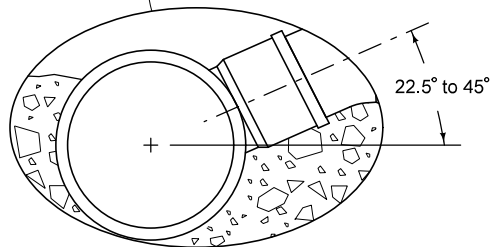
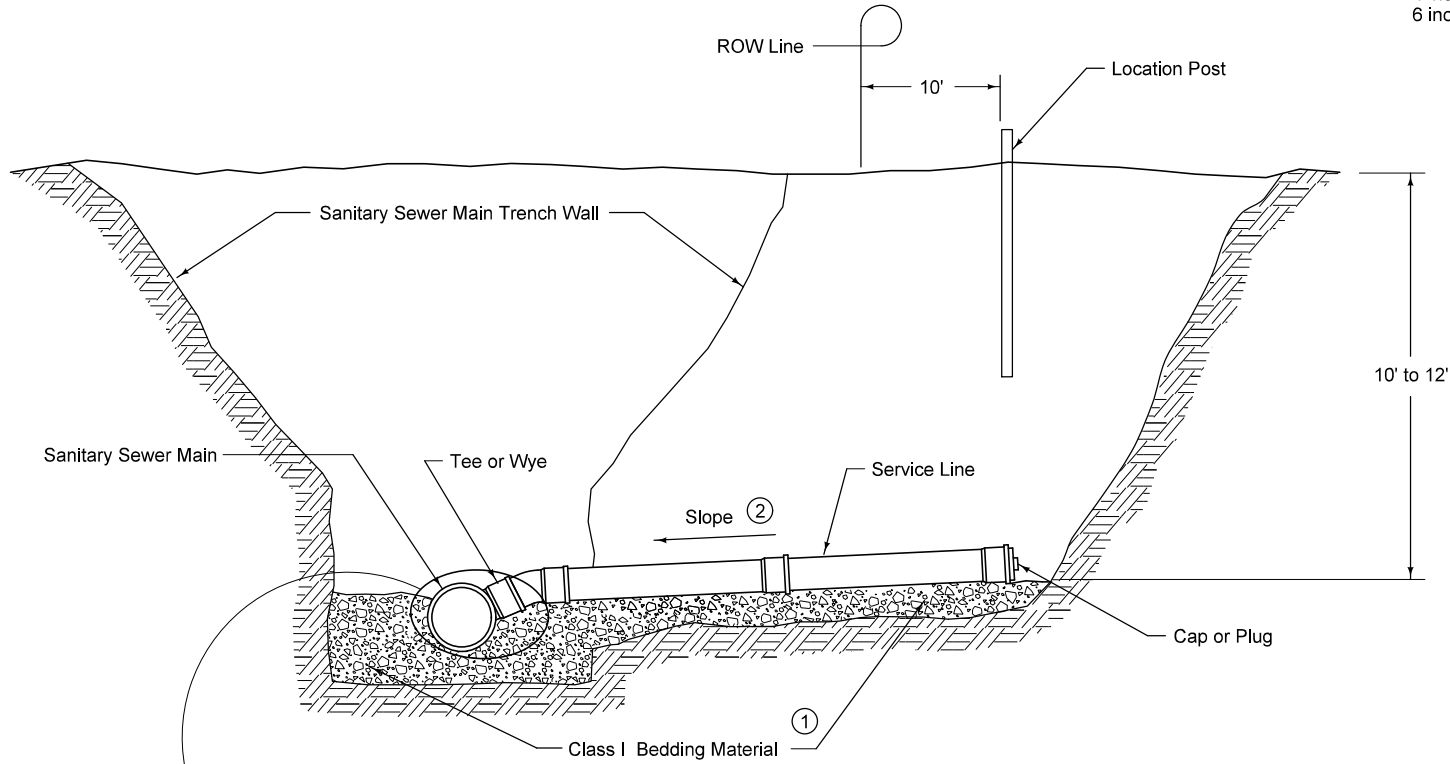

SANITARY SEWER SERVICE STUB

FIGURE 4010.201 SHEET 1 OF 2

SUDAS	IOWADOT	REVISION
		2 04-21-20
FIGURE 4010.201	STANDARD ROAD PLAN	SW-201
		SHEET 1 of 2
REVISIONS: Changed 1 to 1 on Bedding Material.		
Fred D. Wigand SUDAS DIRECTOR		Stuart Miller DESIGN METHODS ENGINEER
SANITARY SEWER SERVICE STUB		

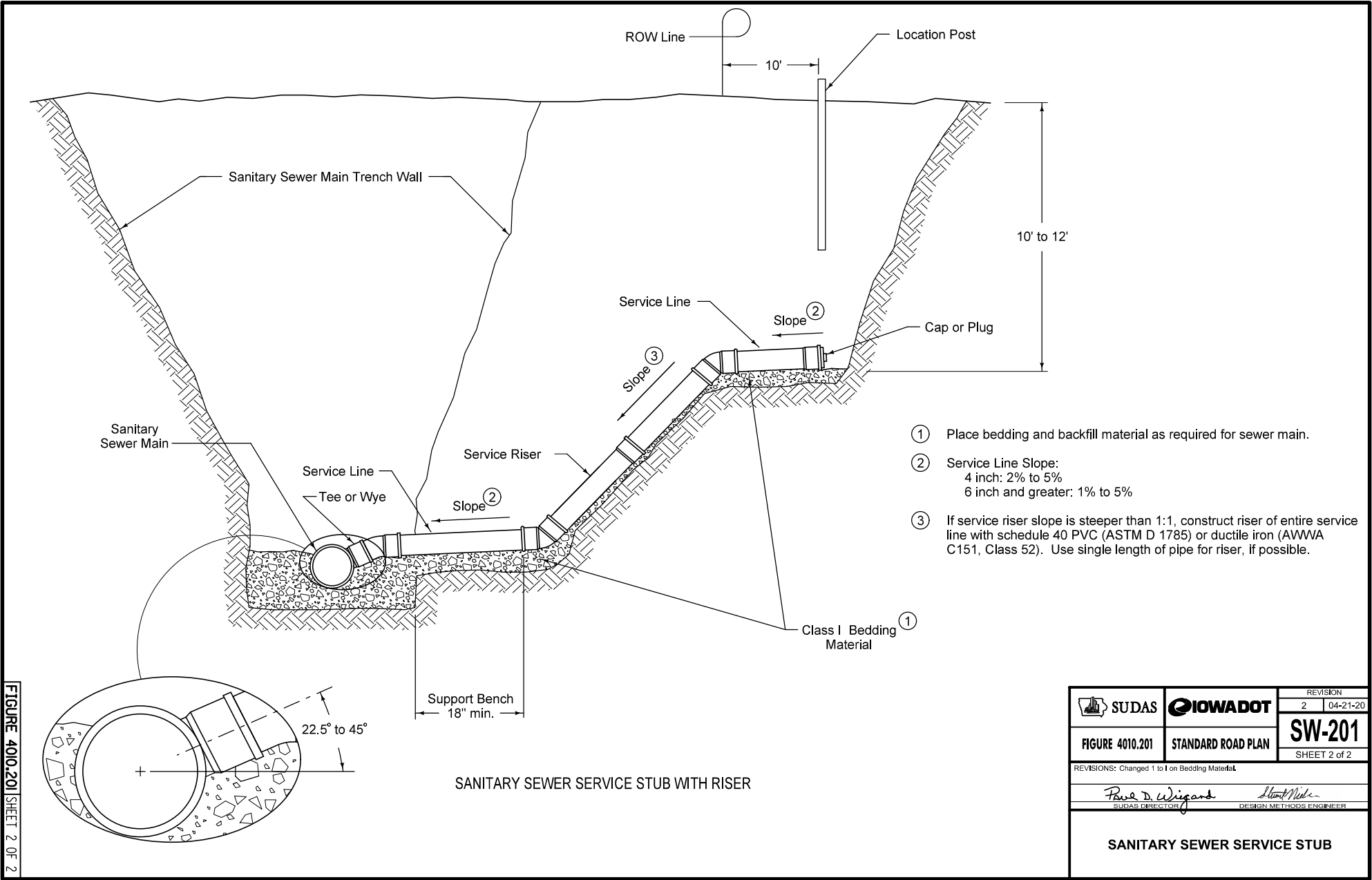

- ① Place bedding and backfill material as required for sewer main.
- ② Service Line Slope:
4 inch: 2% to 5%
6 inch and greater: 1% to 5%
- ③ If service riser slope is steeper than 1:1, construct riser of entire service line with schedule 40 PVC (ASTM D 1785) or ductile iron (AWWA C151, Class 52). Use single length of pipe for riser, if possible.

SANITARY SEWER SERVICE STUB WITH RISER

FIGURE 4010.201 SHEET 2 OF 2

		REVISION
		2 04-21-20
FIGURE 4010.201	STANDARD ROAD PLAN	SW-201
REVISIONS: Changed 1 to 1 on Bedding Material		SHEET 2 of 2
 SUDAS DIRECTOR		 DESIGN METHODS ENGINEER
SANITARY SEWER SERVICE STUB		

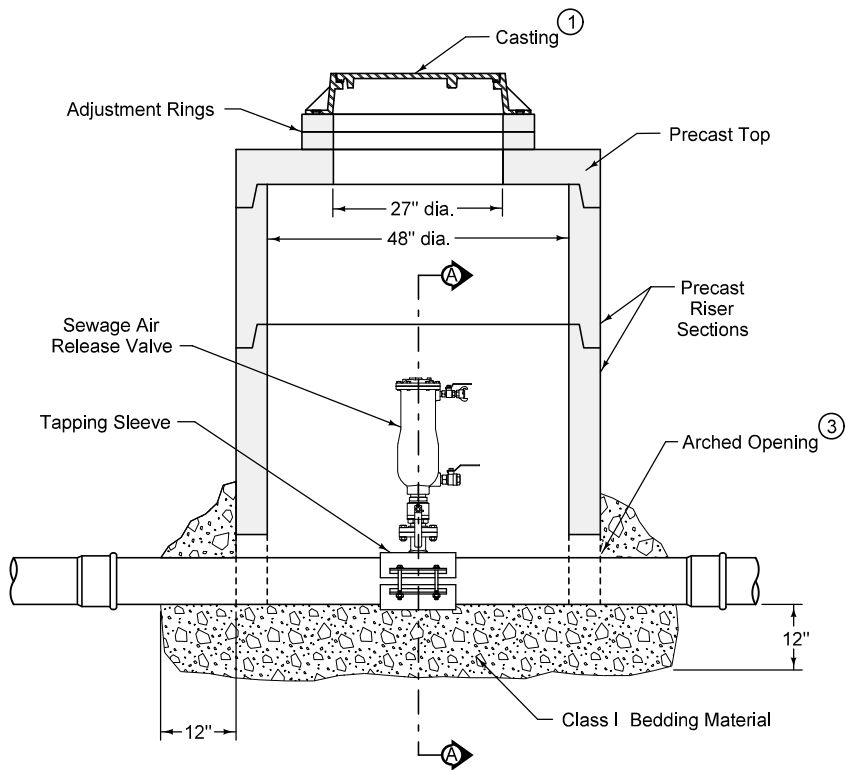

TYPICAL SECTION

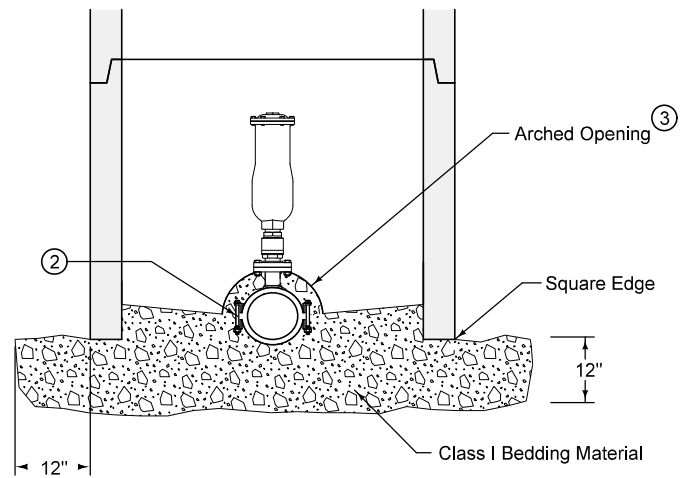

SECTION A-A

- ① SW-601 Type A or SW-602 Type G casting.
- ② Place bedding material to springline of pipe.
- ③ Prevent riser from bearing on pipe by providing an arched opening with a diameter up to 6 inches larger than pipe diameter.

FIGURE 4010.202 SHEET 1 OF 1

SUDAS	IOWADOT	REVISION
		2 04-21-20
FIGURE 4010.202	STANDARD ROAD PLAN	SW-202
		SHEET 1 of 1
REVISIONS: Changed 1 to 1 on Bedding Material		
Paul D. Wigand SUDAS DIRECTOR		Stuart Nadeau DESIGN METHODS ENGINEER
SEWAGE AIR RELEASE VALVE PIT		

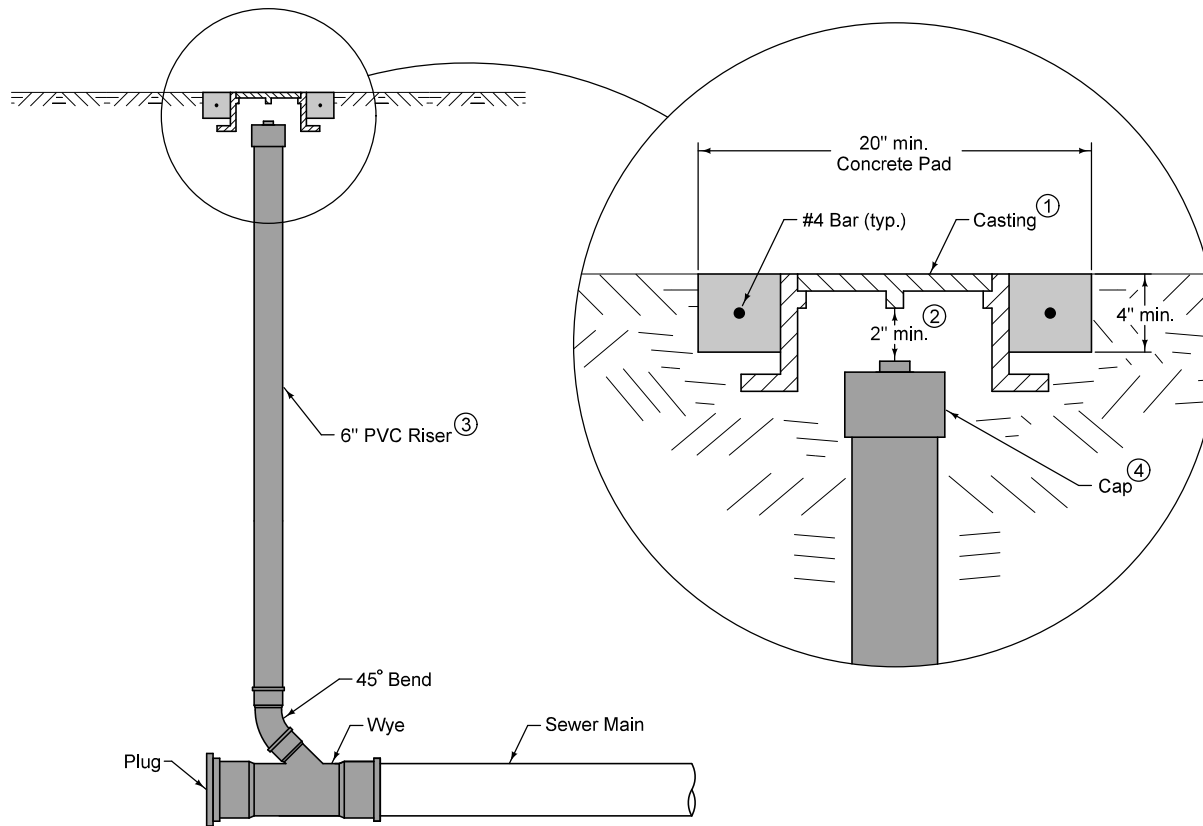

- ① Standard duty casting complying with AASHTO M 306. Mark lid with "Sanitary" or "Sanitary C.O."
- ② Do not allow casting to bear on top of riser pipe.
- ③ 6 inch PVC Service Pipe
- ④ Threaded PVC cap or iron body ferrule with brass screw plug

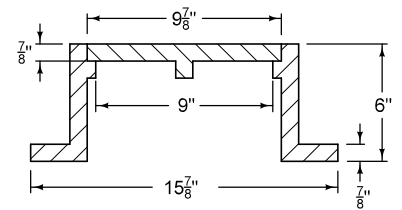

CASTING ①
(Dimensions are nominal)

CLEANOUT

FIGURE 4010.203 SHEET 1 OF 1

		REVISION
		1 04-17-18
FIGURE 4010.203	STANDARD ROAD PLAN	SW-203
		SHEET 1 of 1
<small>REVISIONS: Replaced Iowa DOT and SUDAS logos.</small>		
<i>Paul D. Wigand</i> <small>SUDAS DIRECTOR</small>		<i>Brian Smith</i> <small>DESIGN METHODS ENGINEER</small>
SANITARY SEWER CLEANOUT		

① Zone of conflict is from 6 inches below the bottom of sewer pipe to 2 inches above the top of pipe.

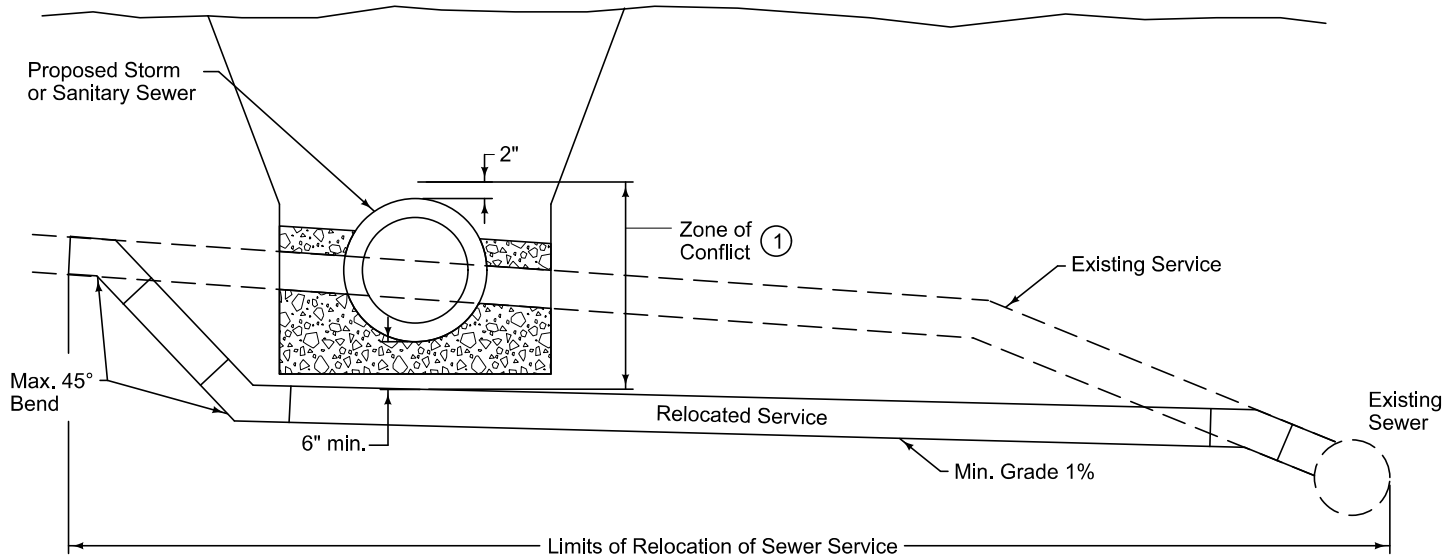

	Service Status	Contractor's Responsibility	Compensation
1.	Service located outside zone of conflict	Provide protection; if damaged, repair according to local government's plumbing code	Incidental to other work
2.	Service located in zone of conflict	Relocate service according to Section 4010, 3.07	Bid item; sanitary sewer service relocation
3.	Service located in zone of conflict, but elevations do not allow simple relocation as detailed above; special design required	Relocate service as directed by the Engineer	Change order

FIGURE 4010.901 SHEET 1 OF 1

	REVISION 1 10-21-14
	SUDAS 4010.901
	SHEET 1 of 1
SUDAS Standard Specifications	
RELOCATE SANITARY SEWER SERVICE IN CONFLICT WITH NEW SEWER	

