

# IMPROVED HYDRAULIC SAFETY FOR COVERED BRIDGES

Frank Jalinoos, Sheila Duwadi, Kornel Kerenyi (FHWA-TFHRC)  
Jerry Shen, Markus Neundlinger (Gennex System/TFHRC)

Second National Covered Bridge Conference  
Dayton, Ohio  
June 5-8, 2013

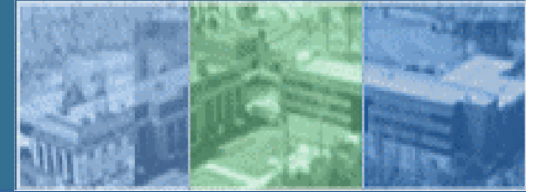



## OUTLINE

- Background
- Hurricane Irene
- Flume Testing for Hydrodynamics Loads at TFHRC Hydraulics Lab
- CFD Modeling at Argonne-TRACC
- Concluding Remarks



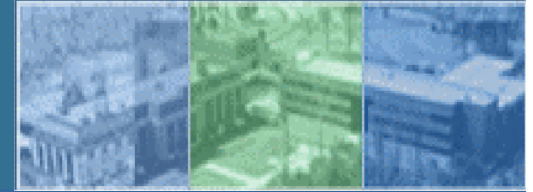

# MAIN CAUSES OF FAILURES OF COVERED BRIDGES

1. Neglect
2. Fire and Arson
3. Floods (Hydraulics)
4. Poor Engineering Design



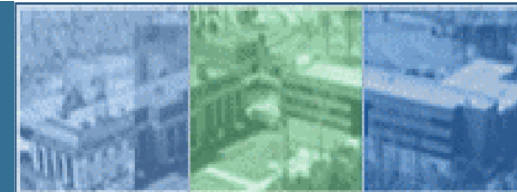

# COVERED TIMBER BRIDGES

- Covered bridges pose a distinct hydraulic risk.
- In a devastating flood of November 1927 in Vermont, about 400 of Vermont's 600 covered bridges were lost in that storm. About 100 covered timber bridges remain in Vermont (~840 in the US)
- Most were NOT rebuilt to their original style, but replaced with new steel and concrete structures.



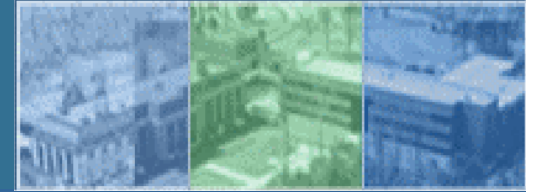

# Hurricane Irene August 2011

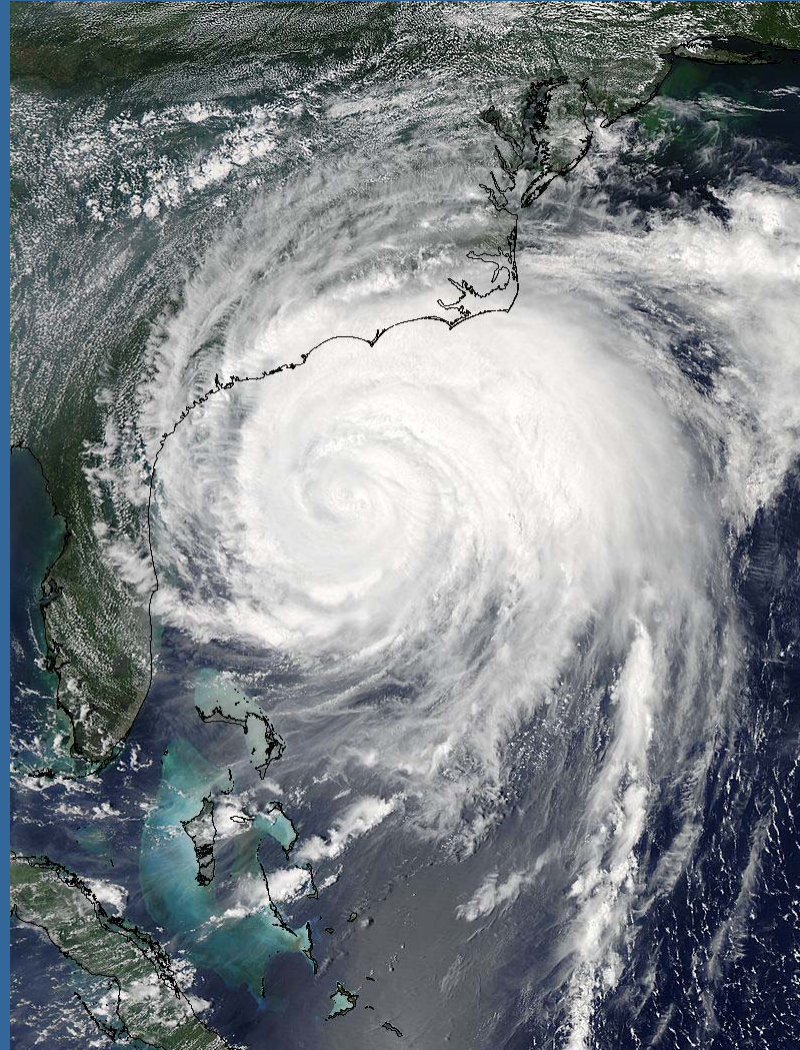



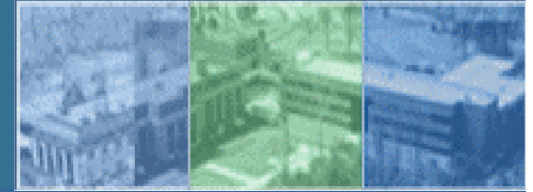

## Erosion and Scour Caused by Hurricane Irene in VT





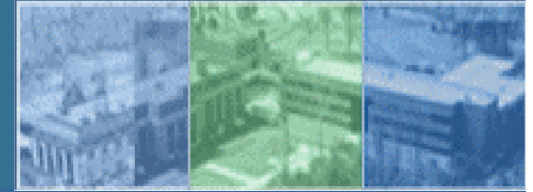

## Erosion and Scour Caused by Hurricane Irene in VT



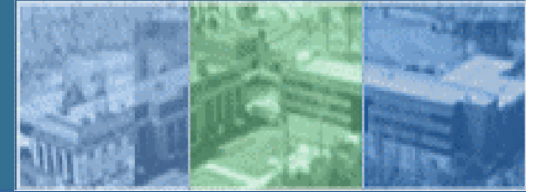

## TROPICAL STORM IRENE

August 28, 2011

- Tropical Storm Irene destroyed two (2) historic (~141 years old) covered timber bridges in Vermont (out of 100), including: 1) Bartonsville Bridge in Rockingham; and, 2) Quechee Bridge near Hartford, VT and damaged several others.
- On November 1, 2011 town officials voted to rebuild the Bartonsville Bridge and on March 7, 2012, voted to rebuild the Quechee Bridge.





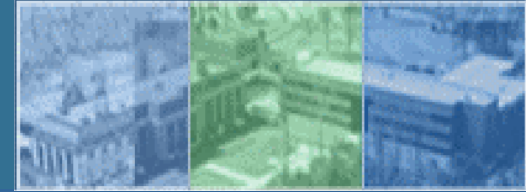

## TROPICAL STORM IRENE

August 28, 2011

- A : Bartonsville Bridge  
Rockingham, VT
- B: Quechee Bridge  
Hartford, VT

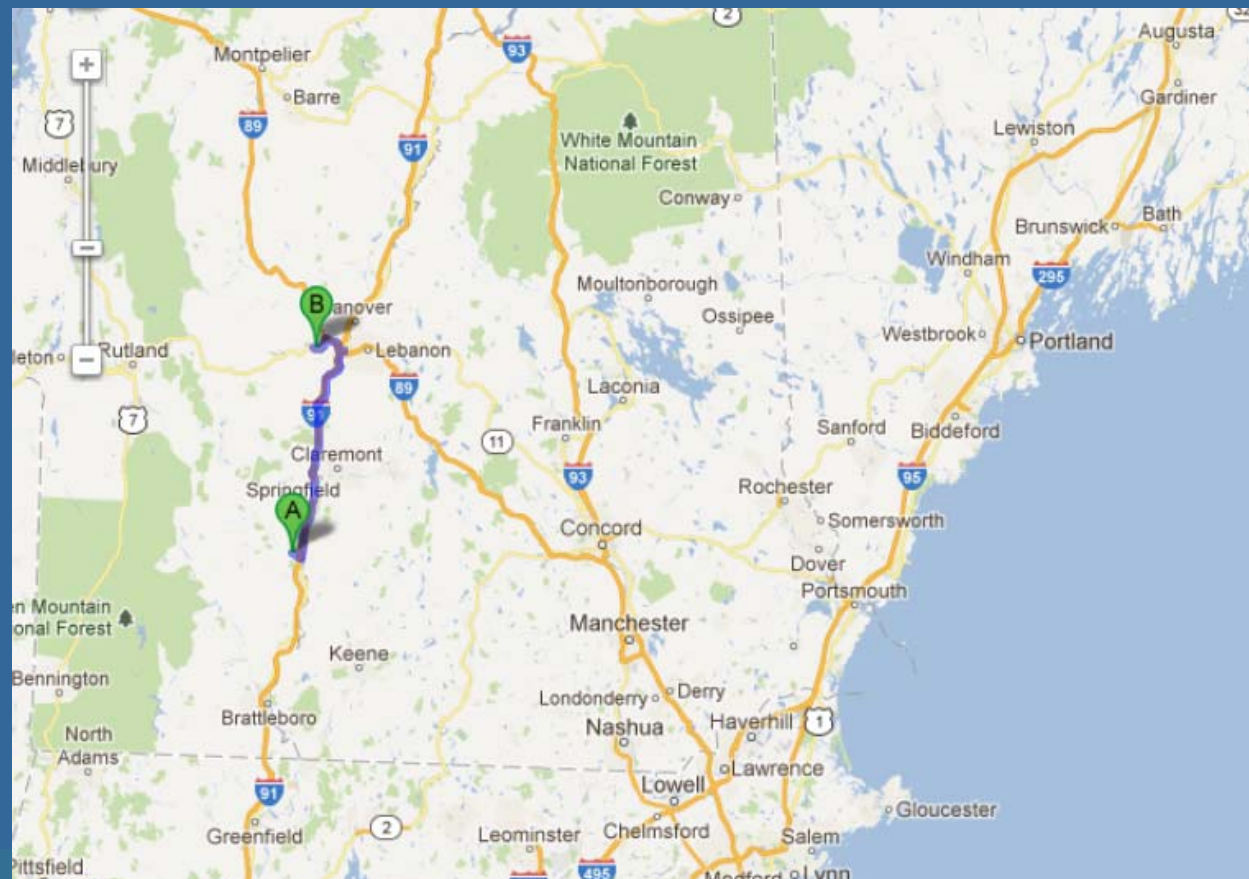

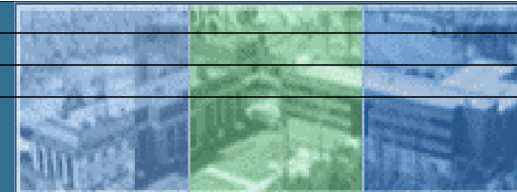

# Hurricane Irene Flooding Quechee Gorge, Vermont Looking from the Route 4 Bridge



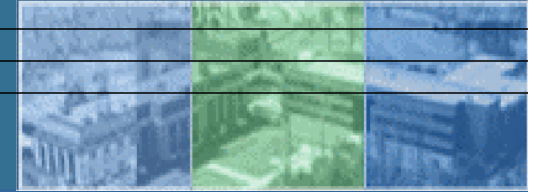

## Lower Bartonsville Covered Bridge

Built 1870, 151' Town Lattice, 3-Ton Posted Load, ADT: 850  
Collapsed into the Williams River , VT (August 28, 2011)





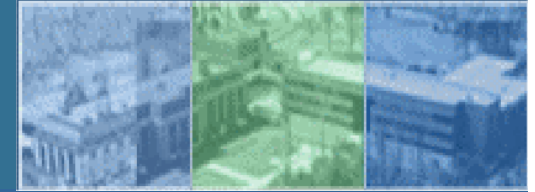

## Lower Bartonsville Covered Bridge

A new covered bridge is being built with an estimated cost of \$2.6 (including the temporary span) being paid with the insurance payout from the old bridge, federal funds and 5 percent match from the state and the town of Rockingham. The bridge should be ready for traffic by early 2013.

Old Bartonsville Bridge – October 2009



C. Hanchey

New Bartonsville Bridge - October 1, 2012;  
Opened 1/26/2013



AP/Wilson Ring





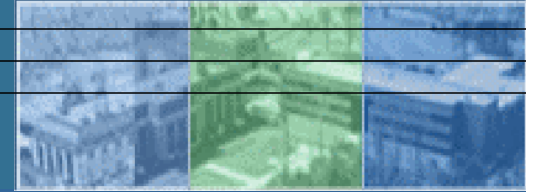

## Flooding from Irene Damaging the Quechee Bridge



## Quechee Covered Bridge

- Steel-Stringer Truss. Built 1870 at Simon Pierce Glass.
- Roughly \$6.5-7 million in municipal damage was estimated.
- On March 7, 2012 Hatford, VT voters approved \$1.8 m bond to rebuild the bridge (FHWA: \$700K, \$1.1 M taxpayers.)
- "The new bridge provides an enlarged hydraulic opening for the Ottaquechee River making it more flood resistant - capable of withstanding another Tropical Storm Irene."

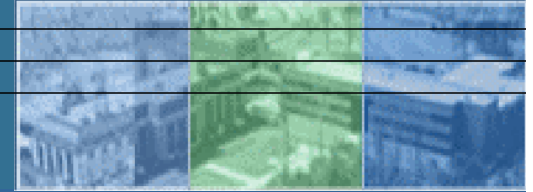

## Tree Hits West Arlington Vermont Covered Bridge





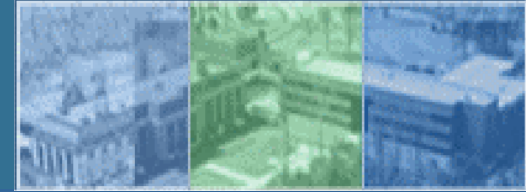

## Tropical Storm Irene

### *Damage in Other States*

- **Greenfield, Massachusetts** - A covered bridge that got washed away along with a road and most of a dam.

- **Blenheim, New York** - Blenheim Covered Bridge, Nichols Powers' 1855 masterpiece spanning 210 ft (64 m) across Schoharie Creek at North Blenheim, New York.

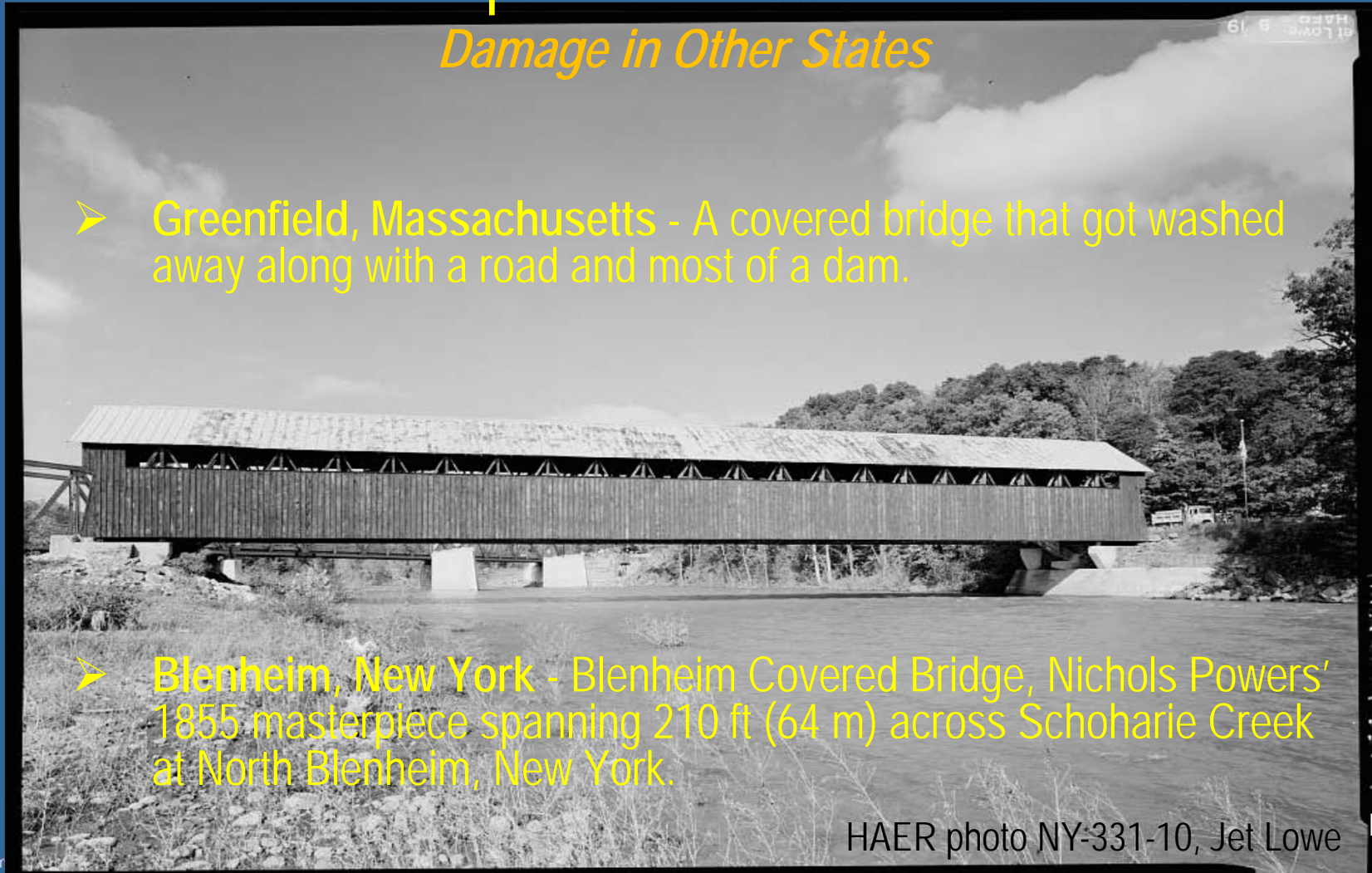



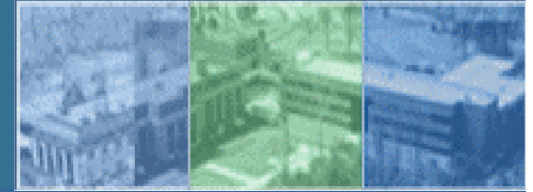

### COVERED TIMBER BRIDGES

- This research will assess the hydraulic vulnerability of a typical covered timber bridge taking into account hydrodynamic loading for partially and fully submerged covered timber bridges.
- Physical modeling, using scaled-down lab specimens, will be performed to calibrate analytical models.



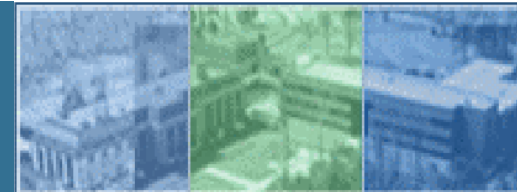

### COVERED TIMBER BRIDGES

- Computational fluid dynamic (CFD) analytical modeling will be used to study the hydraulic vulnerability and hydrodynamic forces on the covered bridges.
- A guidance document will be developed for improving the hydrodynamic performance of the covered bridges. This can include modest design improvements, structural strengthening and rehabilitation measures, and river training and improved hydraulic countermeasures.



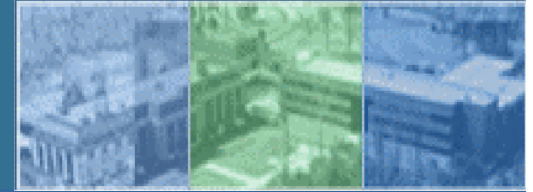

## Physical Modeling Lab at TFHRC in McLean, VA

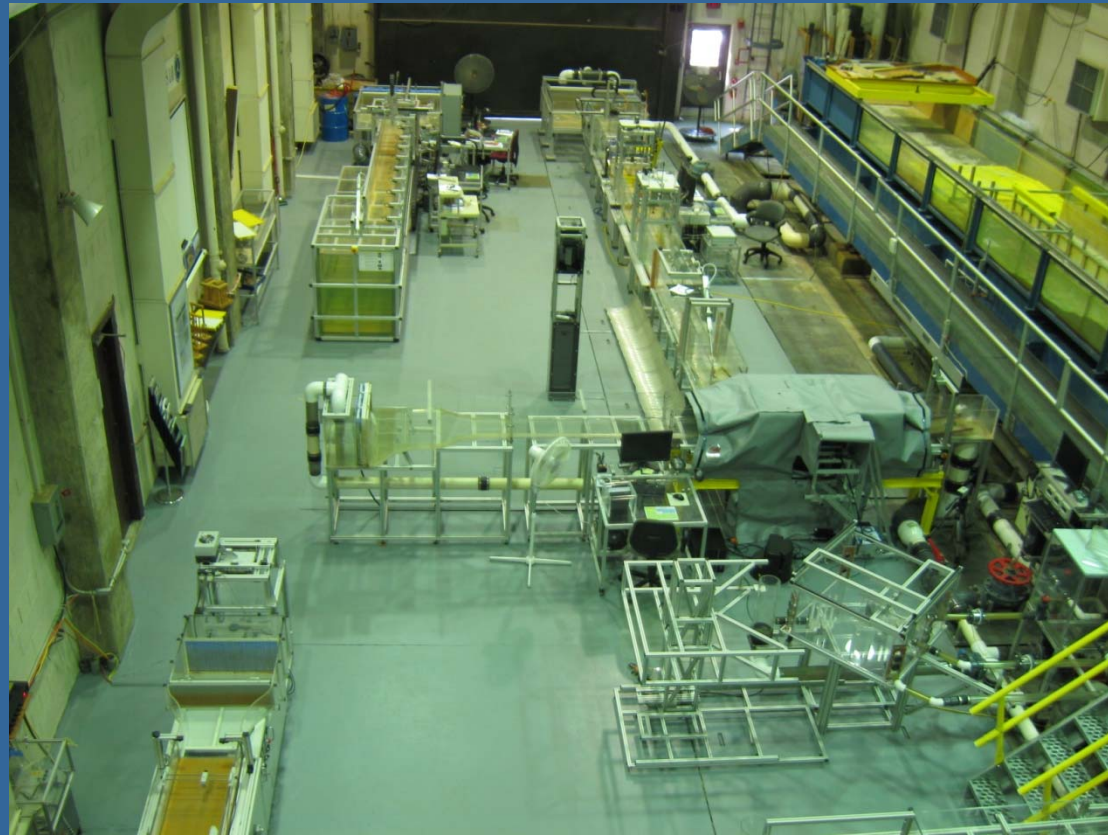

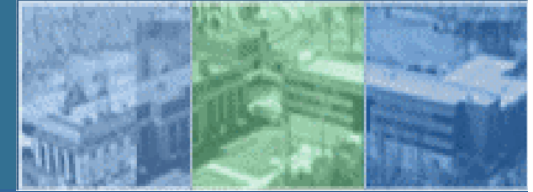

## Force Balance Flume and Force Balance Tower



- Length of the Flume: 45ft
- Max. Flow Rate ~ 1500 gpm
- Max. Water Velocity ~ 5 ft/s





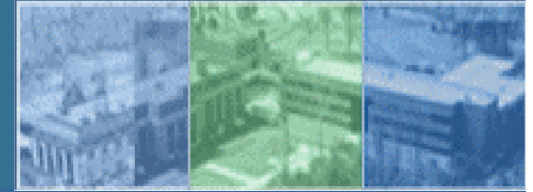

## Force Balance Flume and Force Balance Tower



- Measures the Forces on the Covered Bridges
- Presently, the sensors on the Force Balance Tower are being Replaced in Order to Measure Higher Magnitude Forces



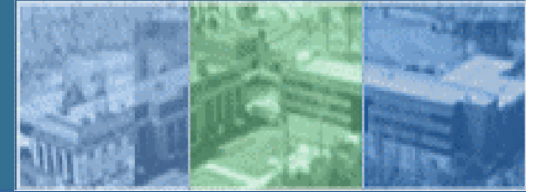

## Drag, Lift and Moments on Inundated Bridge Decks

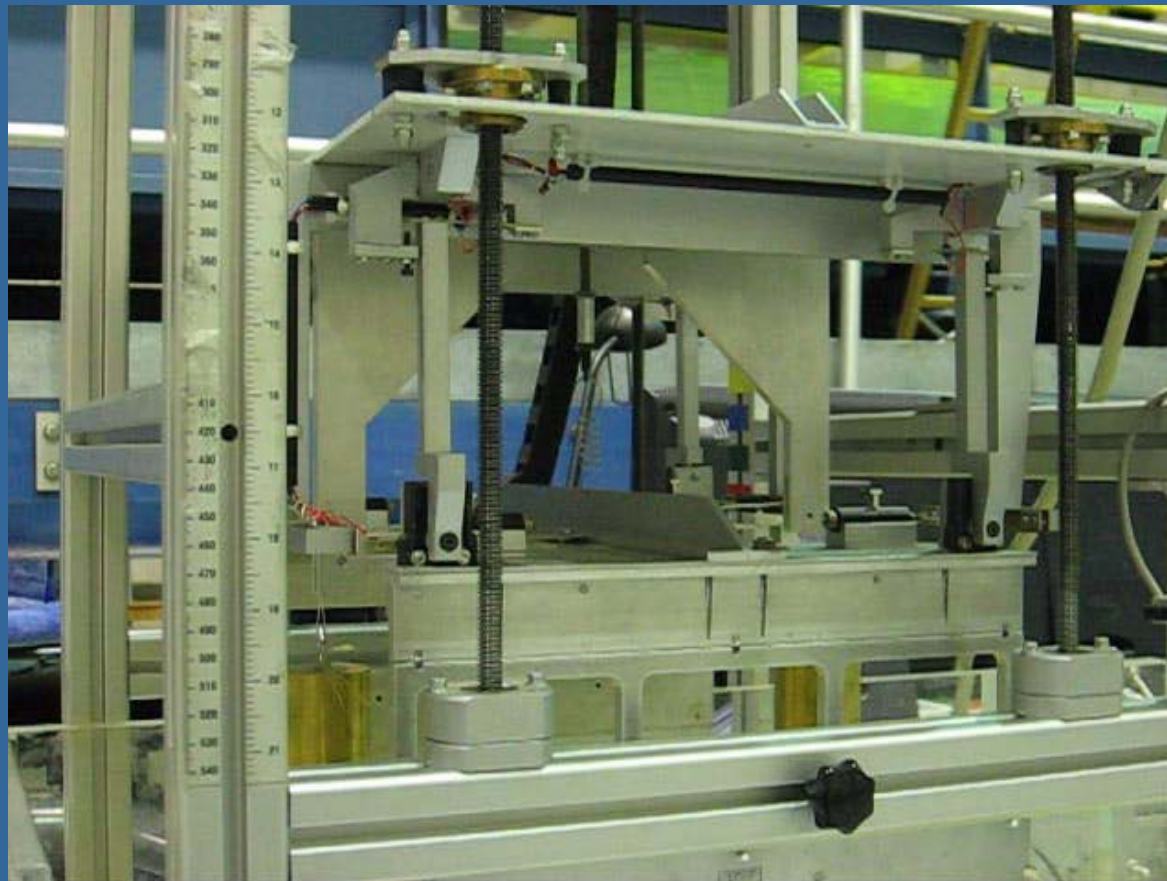

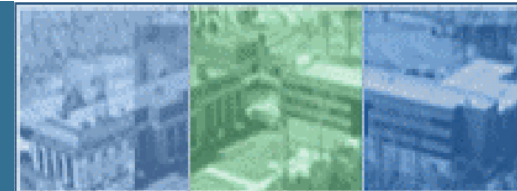

## Particle Image Velocimetry (PIV) Analysis

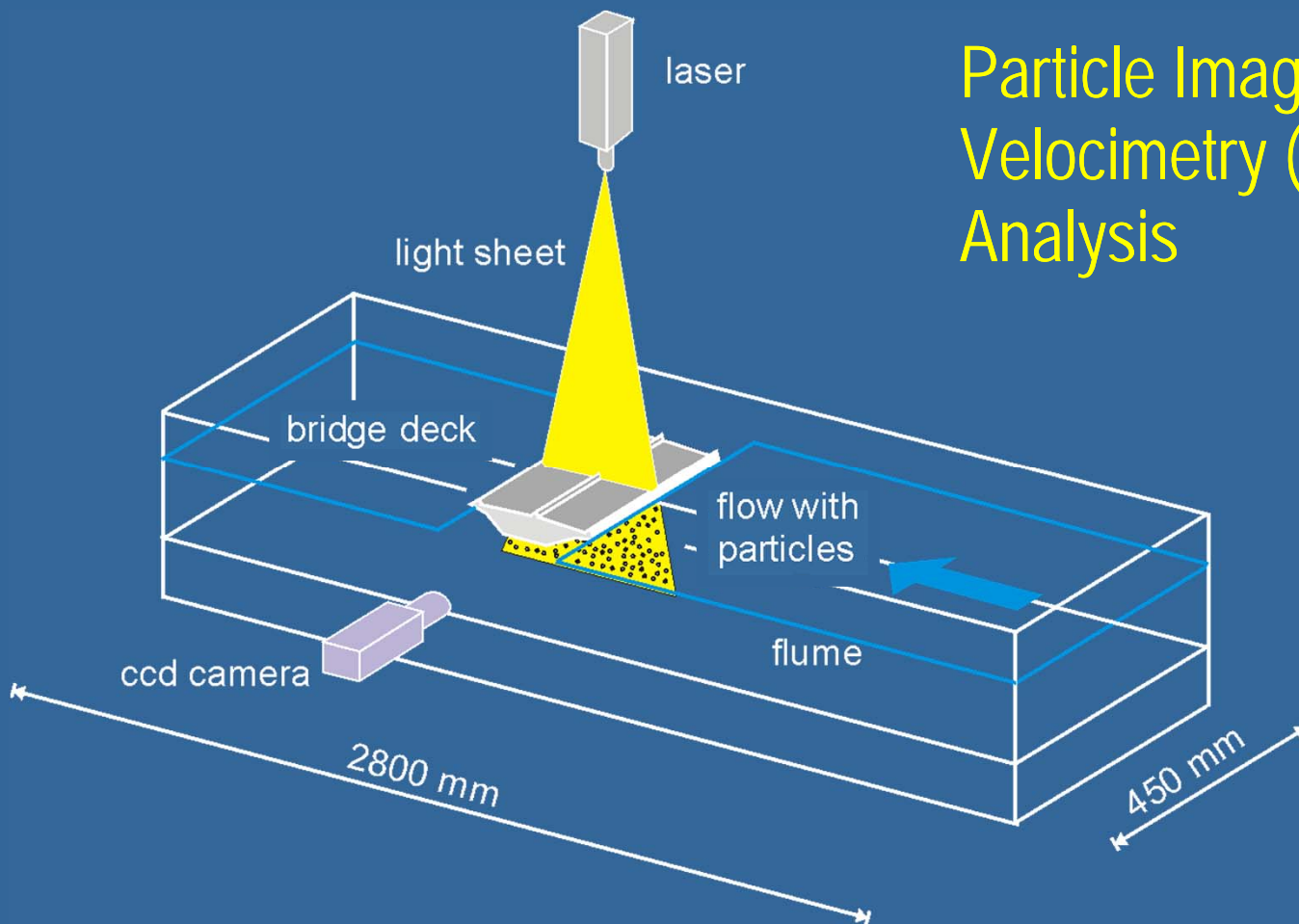

# TURNER-FAIRBANK HIGHWAY RESEARCH CENTER

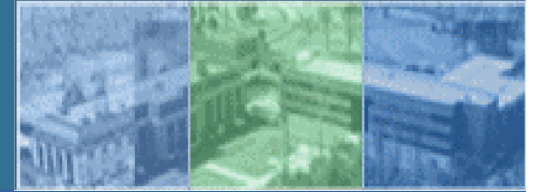

## High Performance Computing Simulation Lab at DOE's Argonne National Laboratory, Argonne, IL





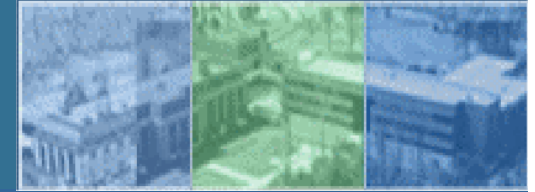

# HYDRODYNAMIC FORCES ON INNUNDATED BRIDGE DECKS

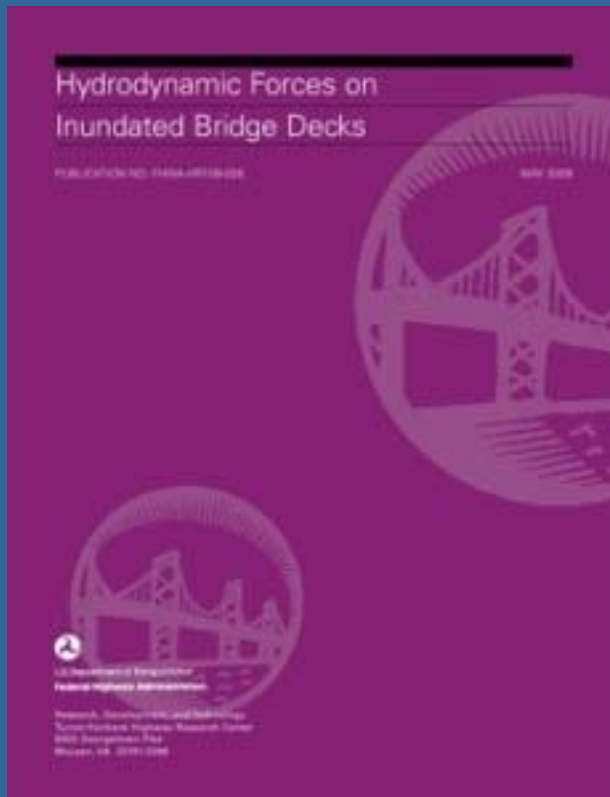

FHWA Report: FHWA-HRT-09-028  
May, 2009

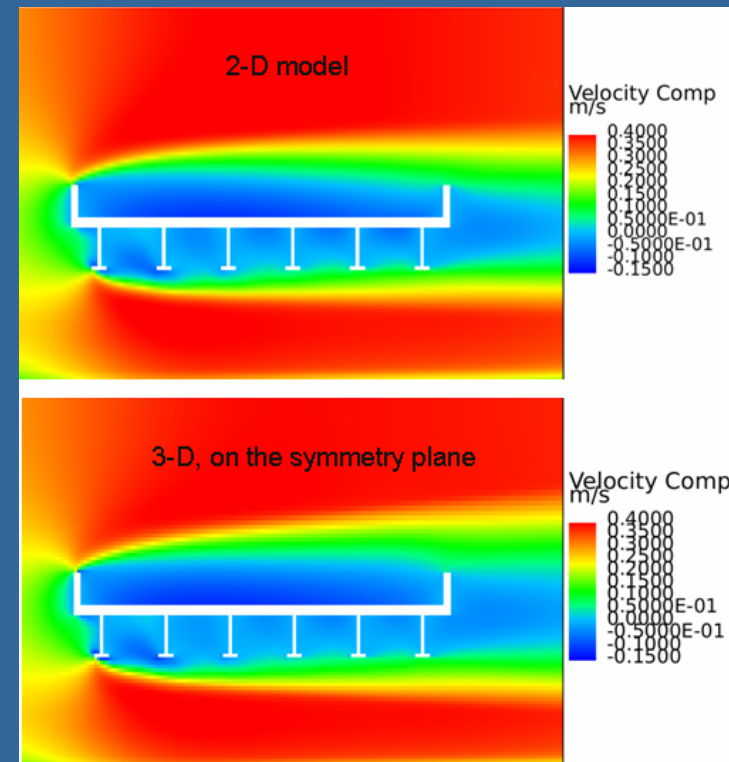

Comparison of flow fields for the 2-D and 3-D models for the STAR-CD® simulations



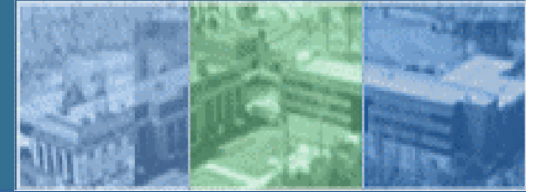

## Velocity Flow Field using PIV

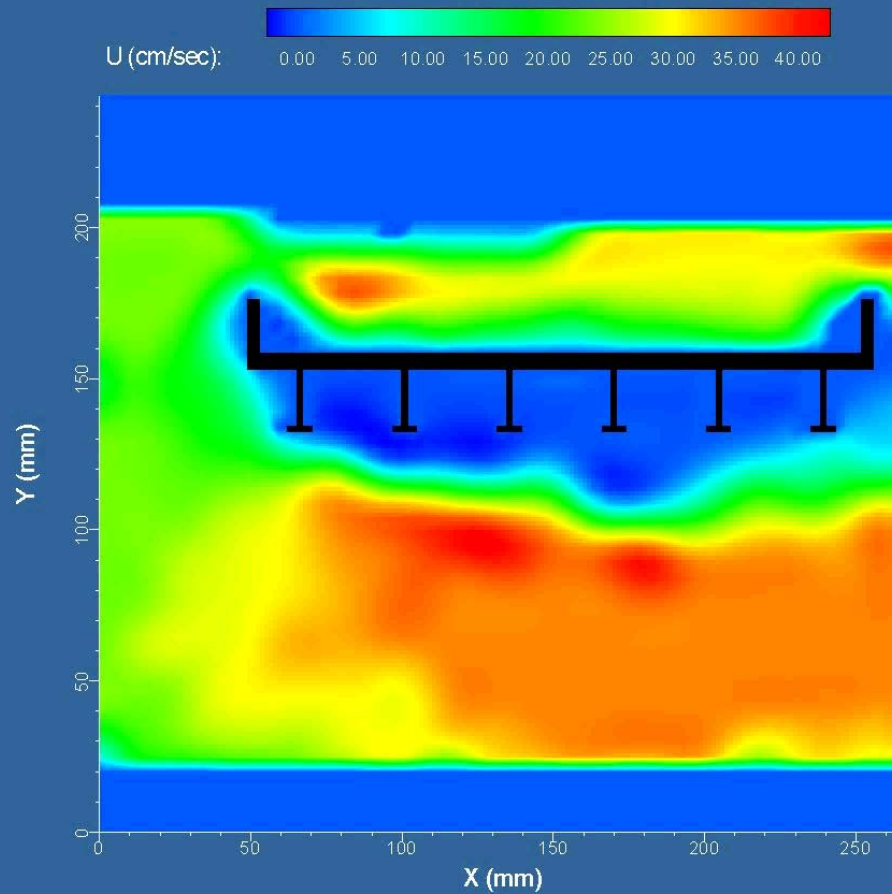

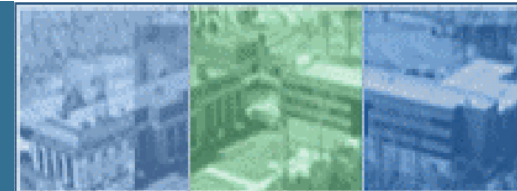

## Velocity Flow Field using CFD Modeling

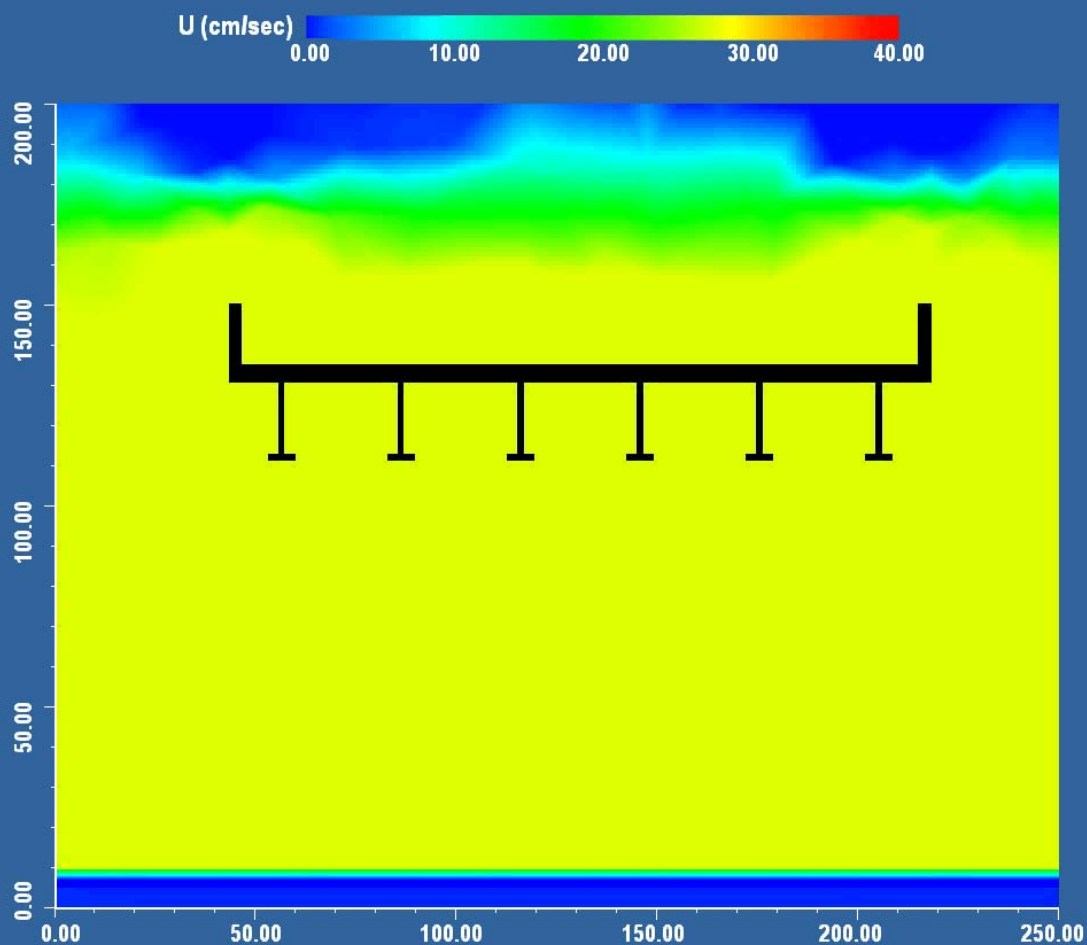

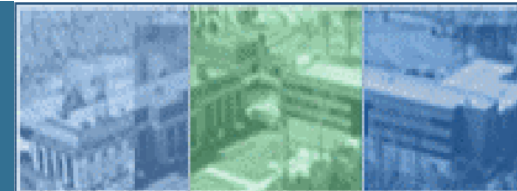

## Drag, Lift and Moments on Inundated Bridge Decks Definition Sketch

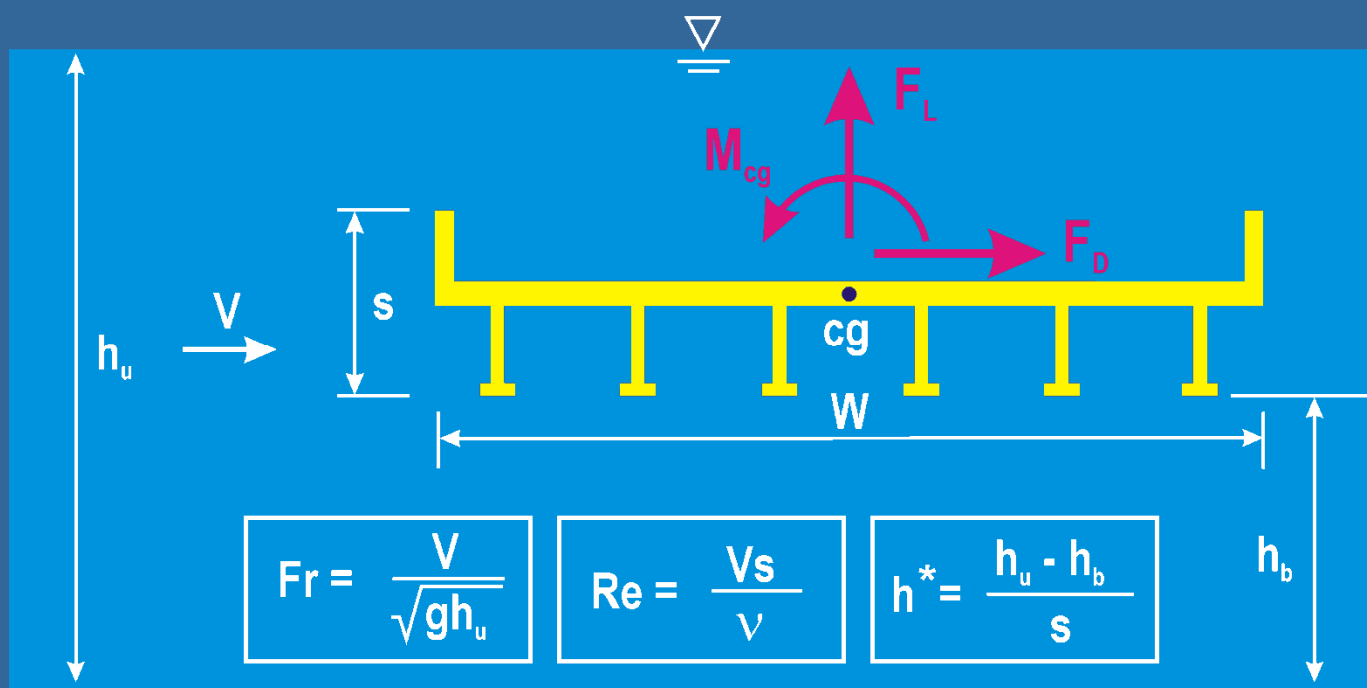



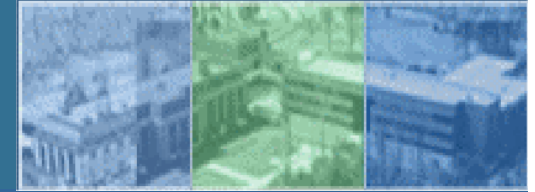

## Drag Force Coefficients Six-Girder Bridge

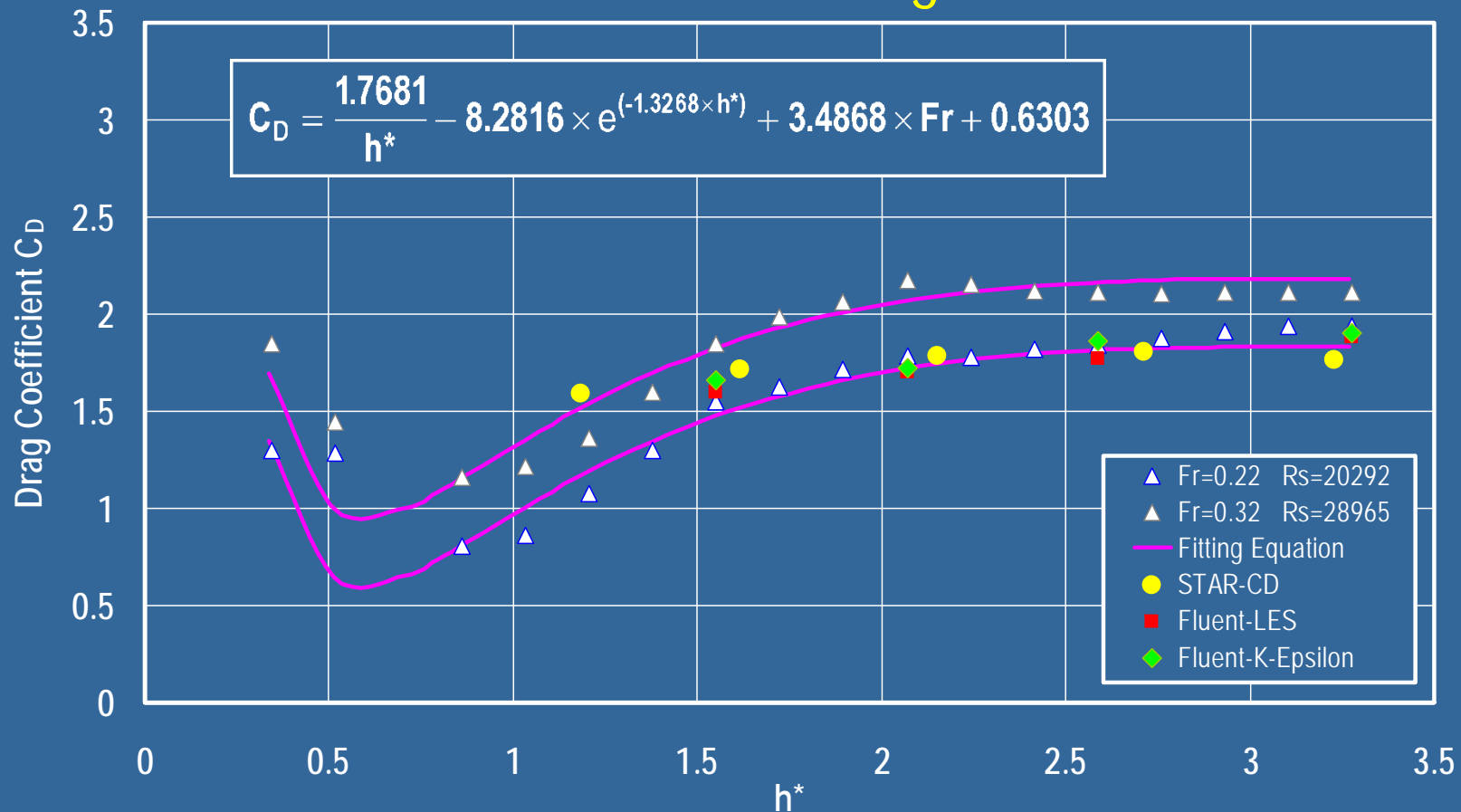

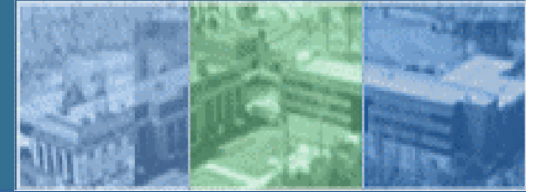

## Lift Force Coefficients

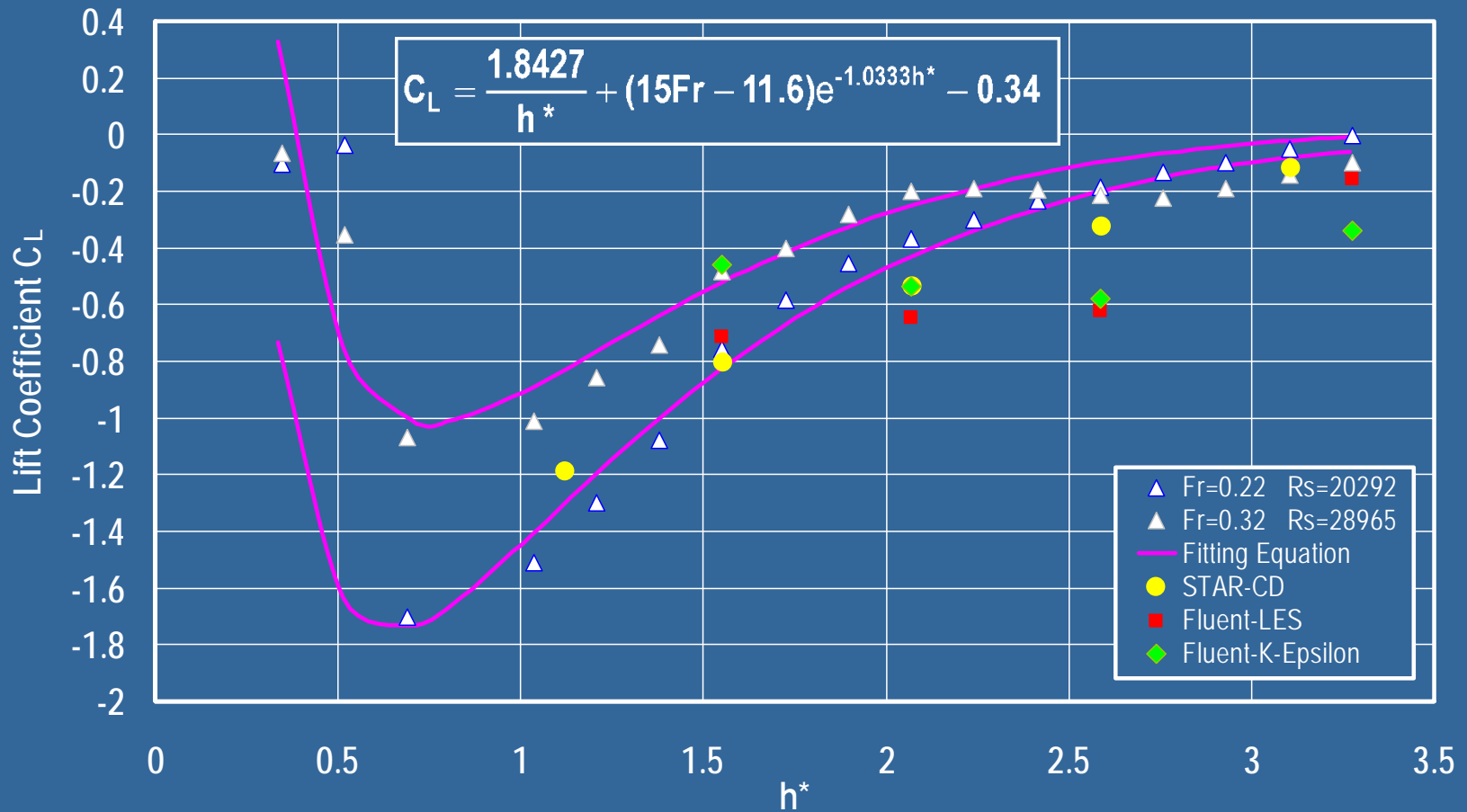

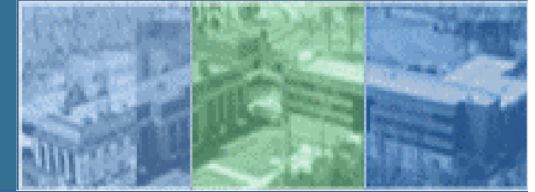

## Moment Coefficients

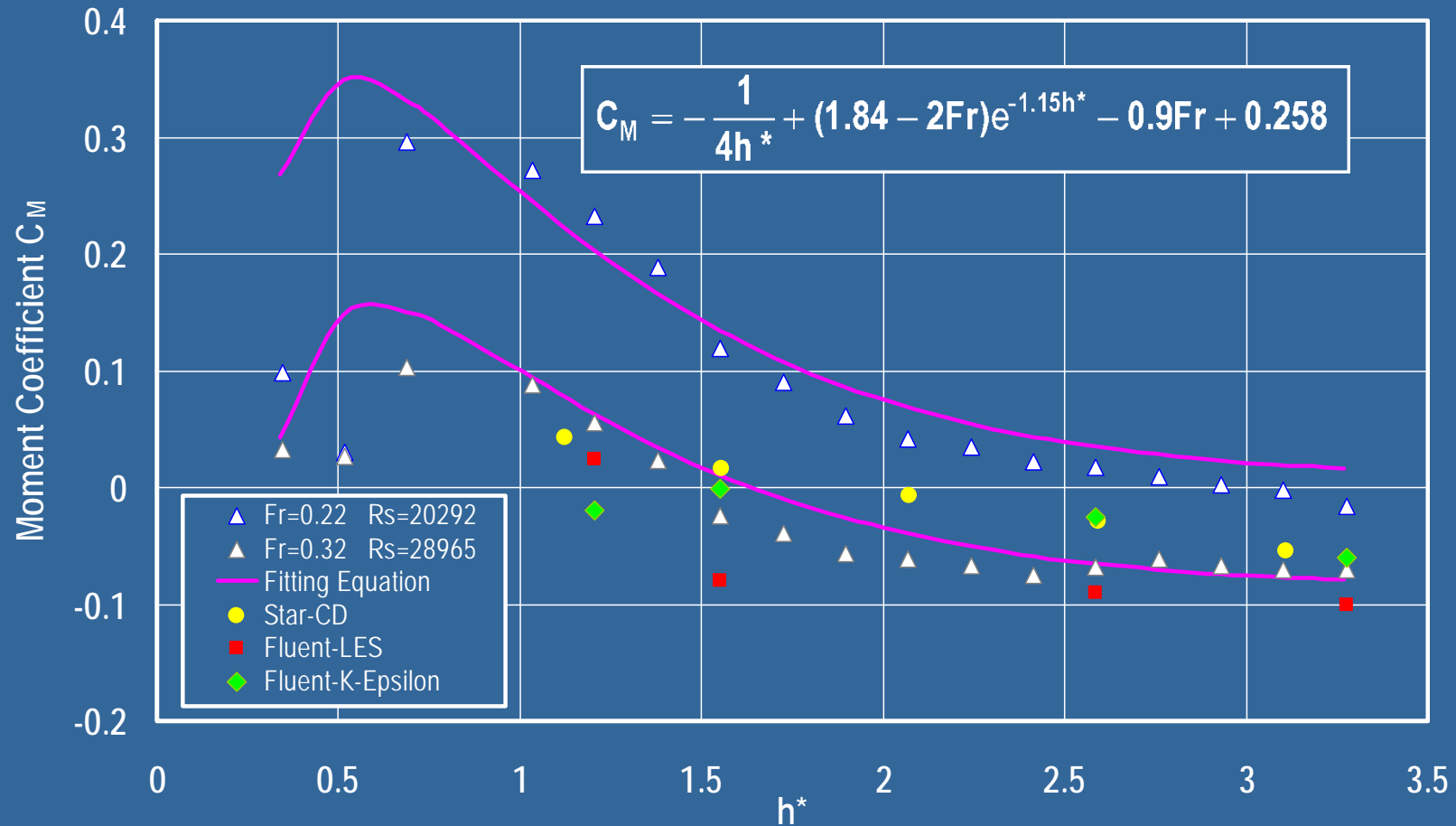

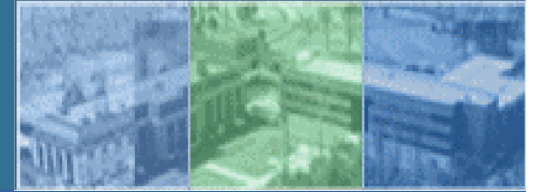

## Most Common Covered Bridge Types with Example Models Built for Testing at the Research Flume

- Town Lattice (Brown Bridge, VT)

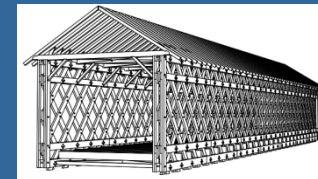

- Howe Truss (Pine Bluff Bridge, IN)

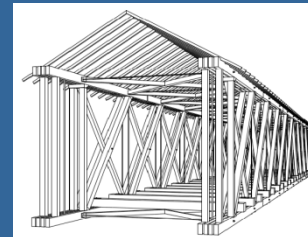

- Burr Arch Truss (Gilpin Falls Bridge, MD)

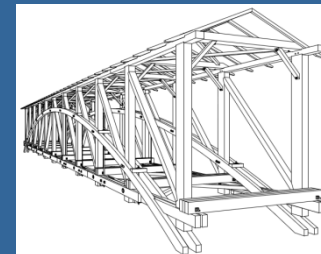



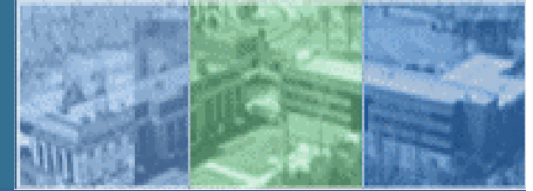

## Brown Bridge CAD Drawing

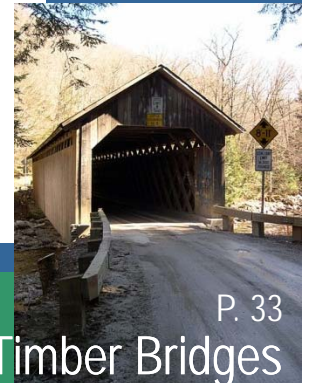
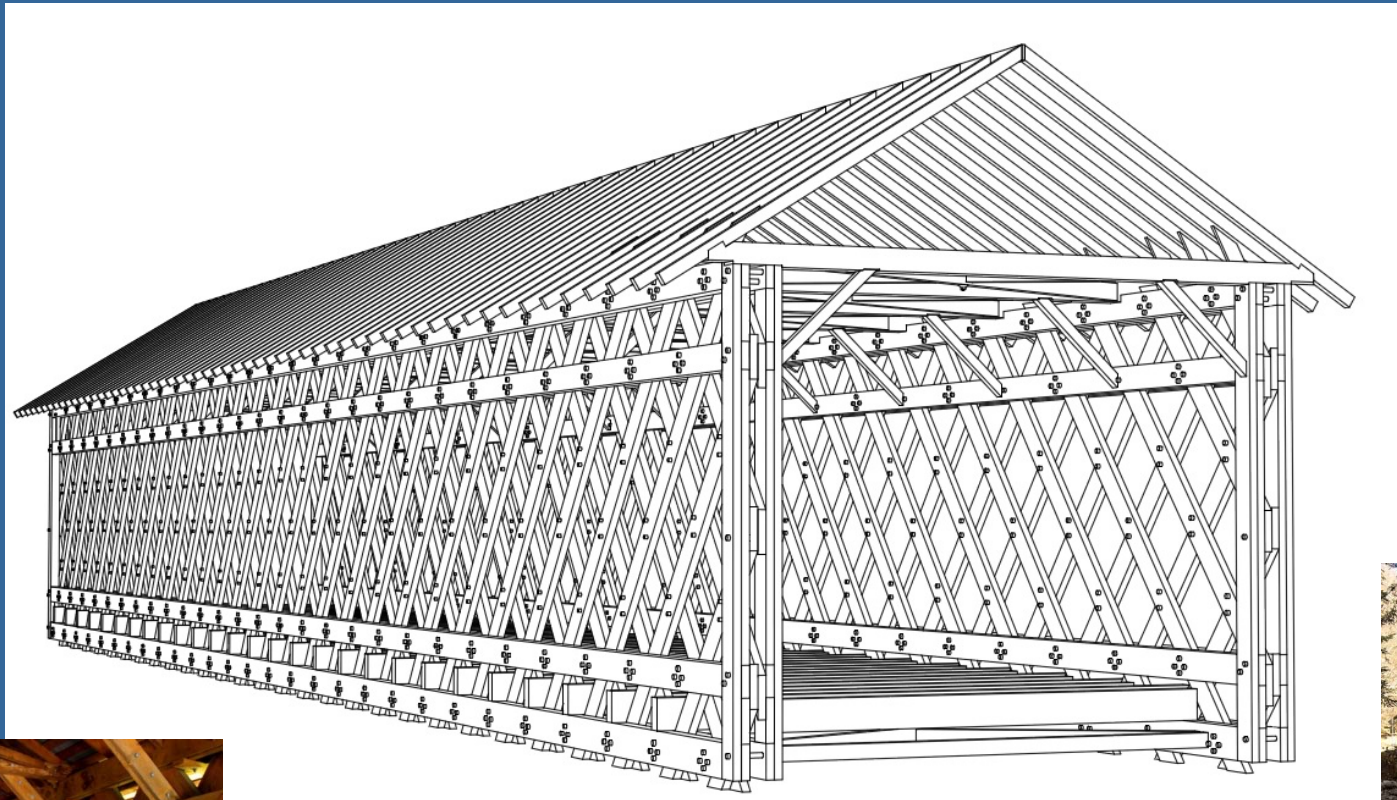

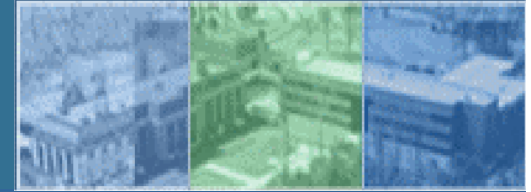

## 3D Printed Model of the Brown Bridge



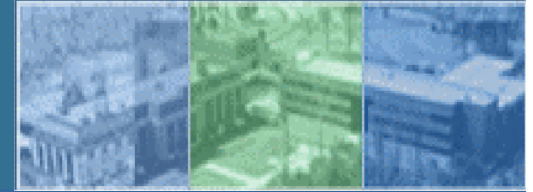

## Howe Truss (Pine Bluff Bridge, IN)

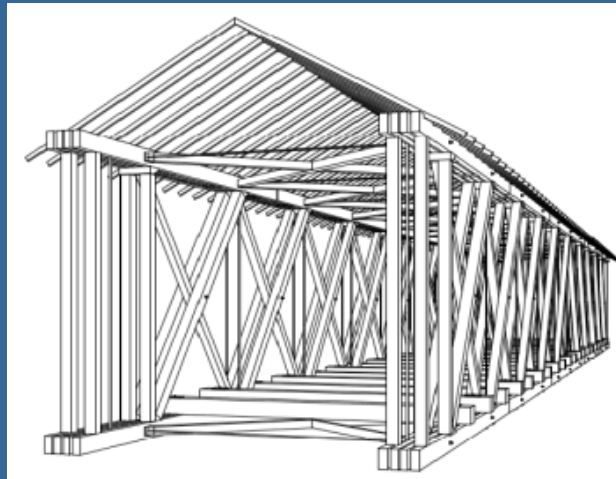



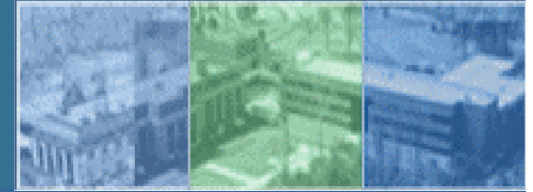

Thank You!

*frank.jalinoos@dot.gov - (202) 493-3082*

*kornel.kerenyi@dot.gov - (202) 493-3142*

*Federal Highway R&D*

