



Evaluation of the Use of Link Slabs in Bridge Projects

tech transfer summary

June 2023

RESEARCH PROJECT TITLE

Evaluation of the Use of Link Slabs in Bridge Projects

SPONSORS

Iowa Highway Research Board
(IHRB Project TR-701)
Iowa Department of Transportation
(InTrans Project 16-566)

PRINCIPAL INVESTIGATOR

Brent Phares, Research Associate Professor
Bridge Engineering Center
Iowa State University
bphares@iastate.edu / 515-294-5879
(orcid.org/0000-0001-5894-4774)

CO-PRINCIPAL INVESTIGATORS

Behrouz Shafei, Associate Professor
Bridge Engineering Center
Iowa State University
(orcid.org/0000-0001-5677-6324)

Travis Hosteng, Assistant Teaching Professor
Civil, Construction, and Environmental
Engineering, Iowa State University
(orcid.org/0000-0002-2059-1296)

MORE INFORMATION

intrans.iastate.edu

Bridge Engineering Center
Iowa State University
2711 S. Loop Drive, Suite 4700
Ames, IA 50010-8664
515-294-8103
www.bec.iastate.edu

The Bridge Engineering Center (BEC) is part of the Institute for Transportation (InTrans) at Iowa State University. The mission of the BEC is to conduct research on bridge technologies to help bridge designers/owners design, build, and maintain long-lasting bridges.

The sponsors of this research are not responsible for the accuracy of the information presented herein. The conclusions expressed in this publication are not necessarily those of the sponsors.

Link slabs offer a promising alternative to expansion joints in accelerated bridge construction projects.

Background

Accelerated bridge construction (ABC) makes use of materials, bridge designs, and construction methods that not only allow for speedy construction but also result in durable and long lasting structures.

The expansion joints commonly used between simply supported bridge spans pose a challenge to the durability and long-term performance of structures built using ABC methods. While these joints provide a gap for the bridge girder and deck system to rotate, expand, and contract, the gap also allows the ingress of corrosive materials and the accumulation of debris that restricts the joint's movement.

A potential alternative to expansion joints is link slabs, which create a continuous bridge deck system while maintaining simply supported girder conditions under the deck. Link slabs eliminate the route for the ingress of corrosive materials and places where debris can accumulate.

Problem Statement

Link slabs are subject to high moments and axial forces imposed by thermal and service loading of the supporting girders and must therefore be very durable and able to withstand high tensile loads. They must also resist cracking to prevent the ingress of corrosive materials.

Though various state departments of transportation (DOTs) have used link slabs effectively, their use is not widespread, and their use with ABC techniques has not been thoroughly explored.

Objective

The objective of this research was to investigate the use of link slabs in conjunction with ABC techniques through a comprehensive set of experimental tests and numerical simulations.

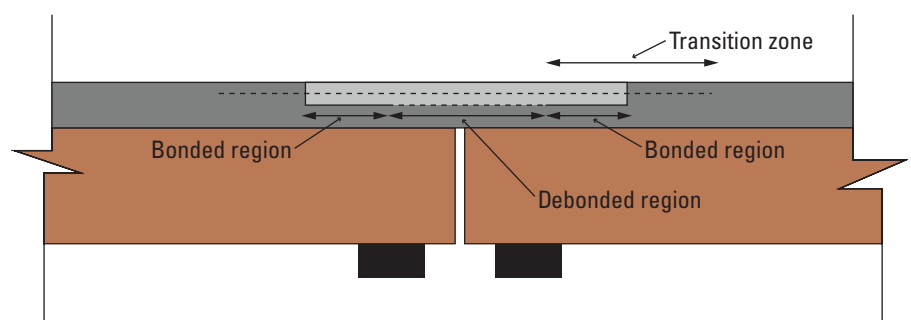

Key features of a link slab

Research Description

Four studies were undertaken for this research.

The first study aimed to select an optimal synthetic concrete fiber type and dosage rate for a durable, constructible, and effective cast-in-place link slab material. Fiber-reinforced concrete (FRC) beam specimens were cast to compare various fiber types and dosages in terms of workability and performance under flexural induced tensile loads and determine the fiber type that most effectively controls cracking. The fibers tested included polypropylene (PP), polyvinyl alcohol (PVA), and alkali resistant glass (ARG).

The second study evaluated the material developed in the first study for its compatibility with embedded steel and glass fiber-reinforced polymer (GFRP) rebar. Mixtures with and without fiber were cast in large, dog-bone shaped specimens and tested under uniaxial tension. The material's performance was also compared to that of commercially available ultra-high performance concrete (UHPC) with steel fibers. Cracking behavior, rebar deformation behavior, and global deformation were related to formulate design recommendations.

In the third study, a full-scale laboratory test was conducted on a half-depth link slab made with FRC to investigate the structural behavior of link slabs under different support conditions. Crack initiation and propagation at ultimate loading were observed to determine the suitability of using FRC for link slabs.

In the fourth study, three-dimensional (3D) finite element (FE) models of a case study bridge with and without link slabs were created to evaluate the feasibility of using link slabs in bridge structures. The study focused on the forces that developed in the bridge pier and deck-girder system for different support conditions.



Laboratory testing setup for full-scale link slab

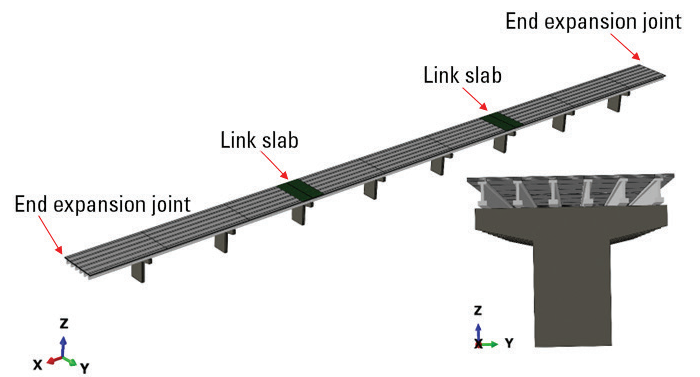

Full-scale 3D FE model of the case study bridge

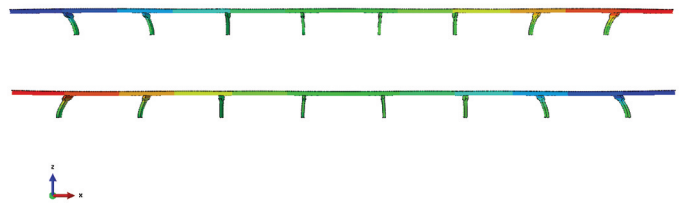
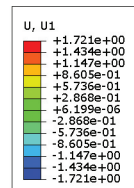

Exaggerated deformation in the FE model with roller support and a link slab under positive (top) and negative (bottom) thermal loading

Key Findings

- ARG macrofibers were more effective at increasing flexural toughness and residual strength than PP or PVA fibers, even though the ARG fibers had a lower aspect ratio, likely due to strong fiber-matrix bond properties provided by the resin coating.
- ARG macrofibers affected concrete fresh properties less than PP or PVA fibers at the same volumetric dose, likely due to their slightly smaller aspect ratio and similar density to the concrete matrix. The increased workability of ARG fiber mixtures makes them more conducive to ease of construction and therefore ABC practice.
- FRC with 1.0% ARG macrofibers may effectively increase load carrying capacity and alleviate strain in the rebar of reinforced concrete after cracking has occurred.

- Laboratory testing of a full-scale link slab showed that the strains in both the concrete and rebar in the bonded region were significantly lower than the strains in the debonded region. This shows the effectiveness of the bonded region in transferring stresses to the debonded region.
- The strain profile along the height of the full-scale link slab showed that the strain distribution in the debonded region varied significantly, while the strain distribution was almost linear in the bonded region.
- The small crack width and the consolidation of small cracks in the debonded region of the full-scale link slab showed the effectiveness of the developed FRC material in limiting crack widths and providing resistance to additional cracking.
- In the case study bridge, when the piers under the link slabs were modeled as roller connections, relatively large stresses developed in the piers between the abutment and link slab. When these bearings were modeled as pinned connections, the stresses in the piers were reduced to a negligible range. This highlights the importance of the boundary conditions assumed for the design and configuration of link slabs.
- The pinned support condition represents the upper limit for stresses in the girder and deck system, while the roller support condition represents the upper limit for stresses in the piers.
- The support conditions affect the strains and stresses in the link slab. The hinge-roller-roller-hinge (HRRH) support case provides the lower bound, while the roller-hinge-hinge-roller (RHHR) support case provides the upper bound.
- The FE analysis showed that link slabs can be beneficial in retrofit situations.

Implementation Readiness and Benefits

The use of link slabs in place of bridge expansion joints is a promising solution in terms of performance, economy, and durability. Link slab applications for ABC include not only expansion joint retrofits in existing simple span bridges but also use with precast deck and girder elements in new construction.

The findings of this comprehensive study provide insight into which FRC mixtures and design configurations are best suited for link slabs in jointless bridges constructed using both ABC and conventional techniques.