2M-3 Street Flow and Intake/Manhole Capacity

A. Introduction

Storm sewer intakes are the main access points by which urban runoff enters the storm sewer system. In fact, the storm sewer intake is an important element of the design in its own right. The hydraulics of flow into an inlet are based on principles of weir and orifice flow, modified by laboratory and field observation of entrance losses under controlled conditions.

Curb and gutter intakes are installed along street sections having curbs and gutters to intercept stormwater runoff and to allow its passage into a storm sewer. Inlets can be located at low points (sumps), directly upstream from street intersections and at intermediate locations as well. The spacing of these intermediate curb inlets depends on several criteria but is usually controlled by rate of flow and the permissible water spread toward the street crown. The type of road is also important since the greater the speed and volume of traffic, the greater the potential for hydroplaning. On the other hand, it is also considered acceptable practice to allow some periodic and temporary flooding of low volume streets (see Section 2A-4 for criteria).

B. Definitions

Frontal flow: The portion of the flow that passes over the upstream side of a grate.

Side-flow interception: Flow that is intercepted along the side of a grate inlet, as opposed to frontal interception.

Slotted drain inlet: A drainage inlet composed of a continuous slot built into the top of a pipe that serves to intercept, collect, and transport the flow.

Splash-over: Portion of the frontal flow at a grate that skips or splashes over the grate and is not intercepted.

Storm sewer intake: A storm sewer intake is an opening into a storm sewer system for the entrance of surface storm runoff. There are four basic types of intakes:

- Curb-grate opening
- Curb opening (or open throat)
- Combination intakes (street intake with manhole)
- Grate intake only (parking lot, driveway, or ditch intake)

In addition, intakes may be further classified as being on a continuous grade or in a low point. The term "continuous grade" refers to an intake so located that the grade of the street has a continuous slope past the intake and therefore ponding does not occur at the intake. The sump or low point condition exists whenever water is restricted to the inlet area because the intake is located at a low point. A low point condition can occur at a change in grade of the street from positive to negative or due to the crown slope of a cross street when the intake is located at an intersection.

Storm sewer manhole: A storm sewer manhole is an access structure for storm sewers.

1. **Design flow.** Design flow is defined as that quantity of water at a given point calculated from the design storm runoff. For gutter applications, design flow should include bypass flow from upstream intakes.
2. **Bypass flow.** Bypass flow is defined as the flow in the gutter that is not intercepted by a given intake. Bypass flow is calculated by subtracting the allowable capacity of the given intake from the design flow assigned to that intake. Bypass flow is added to the design storm runoff for the next downstream intake. As a minimum, intakes at a low point will have design capacity equal to the assigned storm discharge plus upstream bypass flows.

C. Intercepting flows

Storm sewer intakes should be designed to intercept design flow with the following allowable bypass from the system:

1. **Streets on continuous grade.** Downstream intakes should be designed to intercept no less than 50% of the design flow.
2. **Low points and dead-end streets on down grade.** Unless otherwise approved by the Jurisdictional Engineer, intakes should be designed to intercept 100% of the design Flow, or according to Figure 1.

D. Storm sewer structure locations

1. **Access ports (manholes/intakes).** Manholes or other access ports (intakes) are required under the following conditions:
 - a. At the end of each sewer line
 - b. At all changes in pipe size, elevation and grade, or alignment, and at all bends
 - c. At all sewer pipe intersections, except where the size of the storm sewer conduit (54 inches diameter or greater pipe) eliminates the need for a maintenance access. Manholes are required for 54 inches or greater pipes when direct access is desired every 400 feet.
 - d. At all sewer pipe intersections and at intervals not exceeding 400 feet, unless cleaning equipment allows a greater spacing interval. Maximum interval is 500 feet.
2. **Openings**
 - a. **Standard.** The minimum size for an access port (manhole) is 48 inches in diameter. Jurisdictions require concentric manholes, without built-in steps, with the manhole opening over the centerline of the pipe or on an offset not to exceed 12 inches. Some Jurisdictions may allow for eccentric manholes.
 - b. **Special.** For square or rectangular manholes, the manhole openings should be over the centerline of the pipes or on an offset not to exceed 12 inches. The distance from the centerline of the manhole opening to the face of the inside manhole wall should not exceed 30 inches to better facilitate video inspection and maintenance equipment. This may require more than one manhole opening.

c. **Determining diameters.** When utilizing circular precast manholes, it is necessary to determine the diameter required to maintain the structural integrity of the manhole. As a general rule, a minimum concrete leg of 6 inches should remain between the manhole blockouts for adjacent pipes. Determining the required manhole diameter to provide this minimum distance may be done as follows:

- 1) Determine the diameters of, and the angle between, the two pipes in question. If more than two pipes connect at the manhole, the adjacent pipes with the critical configuration (i.e. smallest angle and largest pipes) should be selected. If the critical configuration is not apparent, calculations may be required for all adjacent pipes.

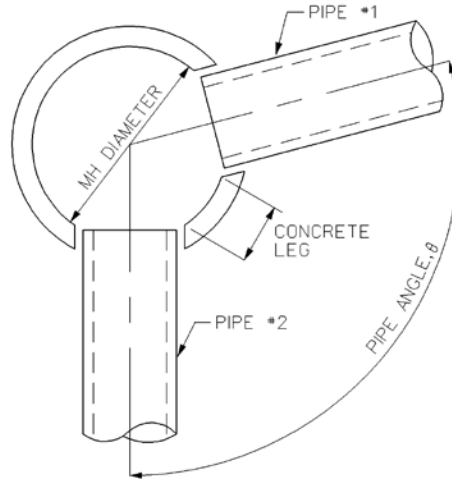

- 2) Determine the blockout diameter. The blockout is the opening provided in the manhole for the pipe. Blockout dimensions are based on the outside diameter of the pipe. For storm sewer, a circular or doghouse type opening is provided with additional clearance to allow for the insertion of the pipe and sufficient space to accommodate placement of concrete grout in the opening. Typical blockout dimensions for various pipe sizes and materials are given in Table 1 below.

Table 1: Manhole Blockout Sizes

Pipe Dia.	Manhole Blockout, in		
	RCP	PVC	DIP
12"	21"	16"	16"
14"	N/A	16"	18"
15"	24"	19"	N/A
16"	N/A	N/A	20"
18"	28"	22"	23"
20"	N/A	N/A	24"
21"	31"	25"	N/A
24"	35"	28"	29"
27"	38"	31"	N/A
30"	42"	35"	36"
33"	47"	N/A	N/A
36"	48"	42"	41"
42"	57"	N/A	N/A
48"	64"	N/A	N/A
54"	71"	N/A	N/A
60"	78"	N/A	N/A

- 3) Determine the diameter of the manhole required to provide the minimum concrete leg dimension. This diameter may be calculated with the following equation:

$$MH_d = \frac{BO_1 + BO_2 + 2CL}{\theta \times \left(\frac{\pi}{180}\right)} \quad \text{Equation 1}$$

where:

MH_d = Manhole Diameter, inches

BO = Blockout Diameter, inches

CL = Minimum Concrete Leg Length, inches (6 inches)

θ = Angle between pipe centerlines, degrees

- 4) Round the minimum manhole diameter calculated, up to the next standard manhole size (48 inches, 60 inches, 72 inches, 84 inches, 96 inches, 108 inches, or 120 inches).
- 5) Verify that the manhole diameter calculated is sufficient for the largest pipe diameter (See Table 2).

Table 2: Minimum Manhole Diameter Required for Pipe Size

<i>Pipe Dia.</i>	Minimum Manhole Diameter Required for Pipe		
	<i>RCP</i>	<i>PVC</i>	<i>DIP</i>
8"	N/A	48"	48"
10"	N/A	48"	48"
12"	48"	48"	48"
14"	N/A	N/A	48"
15"	48"	48"	N/A
16"	N/A	N/A	48"
18"	48"	48"	48"
20"	N/A	N/A	48"
21"	48"	48"	N/A
24"	48"	48"	48"
27"	*60"	48"	N/A
30"	*60"	*60"	*60"
33"	*60"	N/A	N/A
36"	*60"	*60"	*60"
42"	*72"		
48"	*84"		
54"	*96"		
60"	*96"		

*48 inch diameter Tee-section manhole may be used for pipes 27 inches and greater.

2. **Combination intakes.** Intakes with combined manholes will be used when the size of the connecting pipes so indicate or when horizontal clearance is necessary behind the back of curb. The Project Engineer is encouraged to place intakes combined with manholes for storm sewers that are parallel to the street. This will prevent storm sewers from being installed under pavement and thus improves future maintenance access without removing pavement. Approval will be required by the Jurisdictional Engineer when storm sewers or footing drains parallel to the street are placed under the pavement.

3. **Cleanouts.** Lamp holes or clean-out structures are required at the beginning of footing drains and subdrains in street right-of-way. Cleanouts may be permitted in place of a manhole at the end of lines which are less than 150 feet in length.
4. **Access spacing.** Storm sewer structures (manholes, intakes, combination intakes, or cleanouts) in street right-of-way must be located in areas which allow direct access by maintenance vehicles. Areas outside the street right-of-way will be subject to the approval of the Jurisdictional Engineer.
 - a. **Manhole spacing**
 - 1) Manholes are to be spaced at intervals not exceeding 400 feet for sewers 24 inches or less at intervals not exceeding 500 feet when adequate cleaning equipment is available.
 - 2) Spacing of manholes over 500 feet may be permitted in sewers larger than 24 inches if the owner has adequate cleaning equipment.
 - b. **Intake spacing.** Locate street intakes upgrade from intersections, sidewalk ramps, and outside of intersection radius. At least one intake is to be installed at the low point of the street grade.
 - 1) **First intake.** An intake should be located no further than 500 feet from the street high point.
 - 2) **Remaining intakes.** To be spaced at a distance no greater than 400 feet regardless of gutter flow capacity.
1. **Invert drop.** When there is a change in pipe size at a structure, the invert of the smaller sewer must be raised to maintain the same energy gradient. An approximate method of doing this is to place the 0.8 depth point of both sewers at the same elevation. When there is a change in alignment between storm sewer of 45° or greater, the suggested minimum manhole drop is 0.10 foot.

E. Intake capacity

The capacity of an intake is decreased by such factors as debris plugging, pavement overlaying, etc. Therefore, the allowable capacity of an intake is determined by applying the applicable reduction factor from the following table to the theoretical capacity calculated from the design procedures outlined in this section. These reduction factors are based on vane grates, which are required on all curb grate intakes within the street. Other intake grates may be approved by the Jurisdictional Engineer outside of the street right-of-way. The Iowa DOT normally requires curb only intakes on primary roads.

Table 3: Reduction Factors to Apply to Intakes

Intake Type	Location	Reduction Factor ¹	Intake Description
SW-501, SW-502, SW-503, and SW-504	Continuous Grade	90% Vane Grates with Curb	Single Grate with Curb Opening
	Low Point	80% Vane Grates with Curb	
SW-505 and SW-506	Continuous Grade	90% Vane Grates with Curb	Double Grate with Curb Opening
	Low Point	80% Vane Grates with Curb	
SW-507 and SW-508	Continuous Grade	80% Curb Only (No Grate)	Single Open Throat
	Low Point	70% Curb Only (No Grate)	
SW-509 and SW-510	Continuous Grade	80% Curb Only (No Grate)	Double Open Throat
	Low Point ²	70% Curb Only (No Grate)	
SW-501 and SW-502 (Driveway Grate)	Continuous Grade	75% Grate Only (No Curb)	Single Grate Only
	Low Point	65% Grate Only (No Curb)	

¹ Minimum reduction factor is to be used to reduce intake capacity.

² Use of driveway grates at low points is discouraged due to their tendency to become plugged with debris and flood the surrounding area. Obtain permission of the Jurisdictional Engineer prior to placing a driveway grate in a low point. If allowed, the Jurisdictional Engineer may also require installation of standard curb intake(s) immediately upstream of the driveway.

1. Abbreviations

a = Intake Depression in Inches

d = Depth of Flow in Gutter at Face of Curb

h = Height of the Curb Opening

H = Total Head in Feet = d + a in Feet

K = Value Used in Equation $Q = Kd$ (See Figures 3 and 5)

L = Length of Curb Opening in Feet

n = Manning's Roughness Coefficient = 0.016

Q = Discharge in cfs

Q_{CO} = Flow Intercepted by the Curb Opening

Q_G = Flow Intercepted by the Grate

Q_I = Allowable Flow Intercepted by the Intake

R_F = Reduction Factor

S_L = Longitudinal Street Slope

S_T = Transverse Street Slope or Crown

T = Spread of Water in Gutter From Face of Curb

Z = 1/S_T = Reciprocal of Transverse Slope

2. Equations

a. **Capacity of gutter for straight crown.** Figure 1 is the nomograph used to determine the gutter capacity for a straight crown or segmented straight crown. Figure 1 can also be used to approximate the capacity of curved crowns.

b. **Capacity of grate type intakes on a continuous grade.** The allowable capacity of SW-501, 502, 503, 504, 505, and 506 grate-type intakes on a continuous grade is determined by the following equation:

$$Q_I = K \left(d^{\frac{5}{3}} \right) (R_F)$$

Figure 3 is used to determine "K" for a vane grate and includes the curb hood. Figure 4 gives "K" for a driveway condition where no curb hood can be used. The appropriate reduction factor from Table 1 must then be applied to obtain the actual flow intercepted by the intake.

- c. **Capacity of curb opening (open-throat) intakes on a continuous grade.** Figure 2 is used to determine the interception ratio of the SW-507, 508, 509, and 510 intakes. This theoretical interception ratio (Q_i/Q) multiplied by the design flow in the gutter and the reduction factor equals the flow intercepted by the intake.
- d. **Capacity of grate-type and curb opening-type intakes at a low point.** Figure 5 is used to determine the capacity Q of a grate with curb opening, grate only, and curb-opening type intakes at a low point. The appropriate reduction factor must be applied to the results.

Figure 1: Nomograph for Capacity of the Gutter for Straight Crown

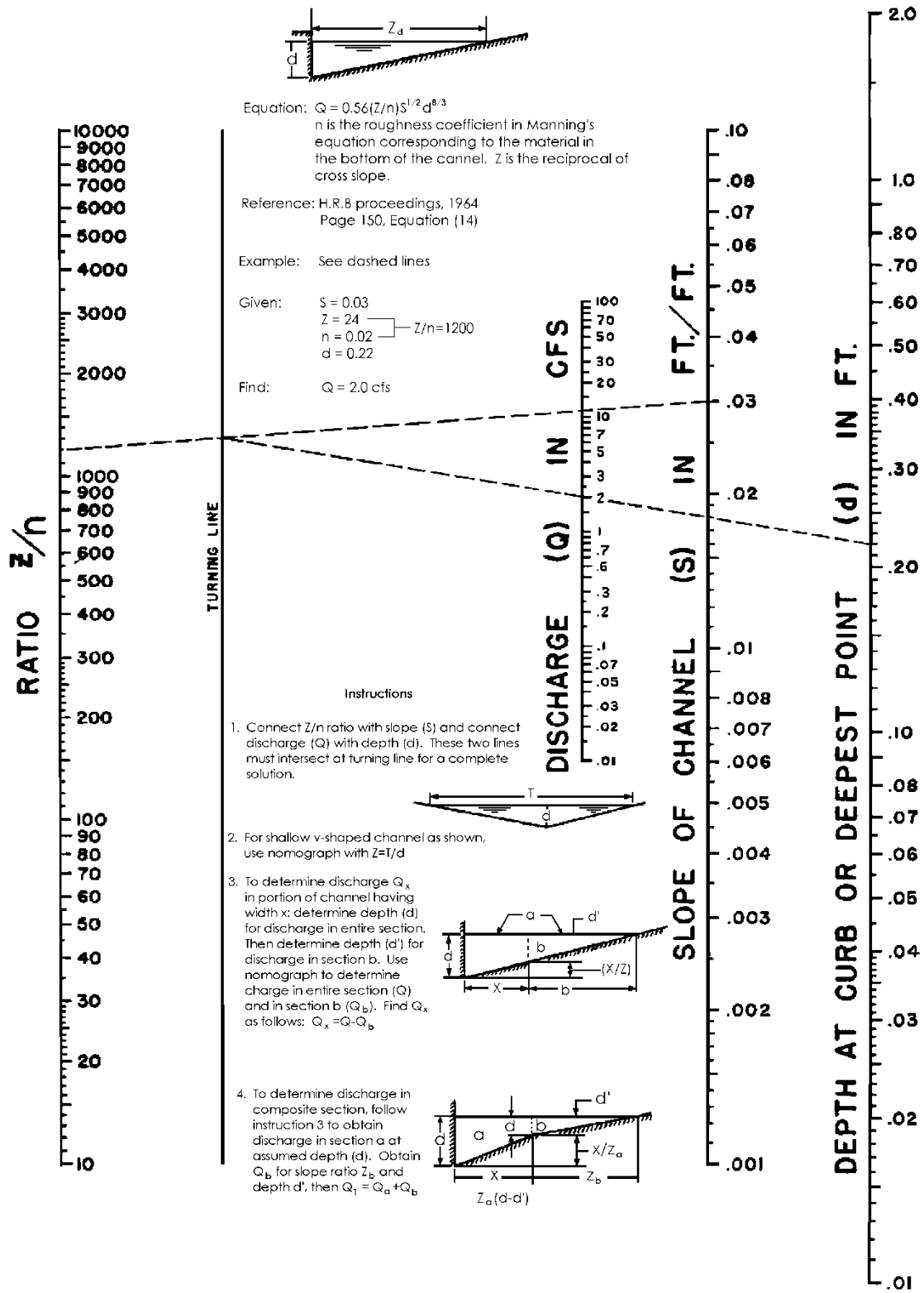

Figure 2: Interception Ratio for Standard Type SW-507, 508, 509, and 510 Intakes on Continuous Grade

STANDARD CURB - OPENING INLET CHART

EXAMPLE

W = 2 ft
 a = 2 in
 h = 6 in

Given: $S_T = 0.02$ ft/ft
 T = 10 ft
 $S_L = 0.03$ ft/ft
 Find: $L_i = 4$ ft $L_i = 8$ ft

$Q_i/Q = .22$ $Q_i/Q = 0.48$
 $d_w = S_T(T-2)$

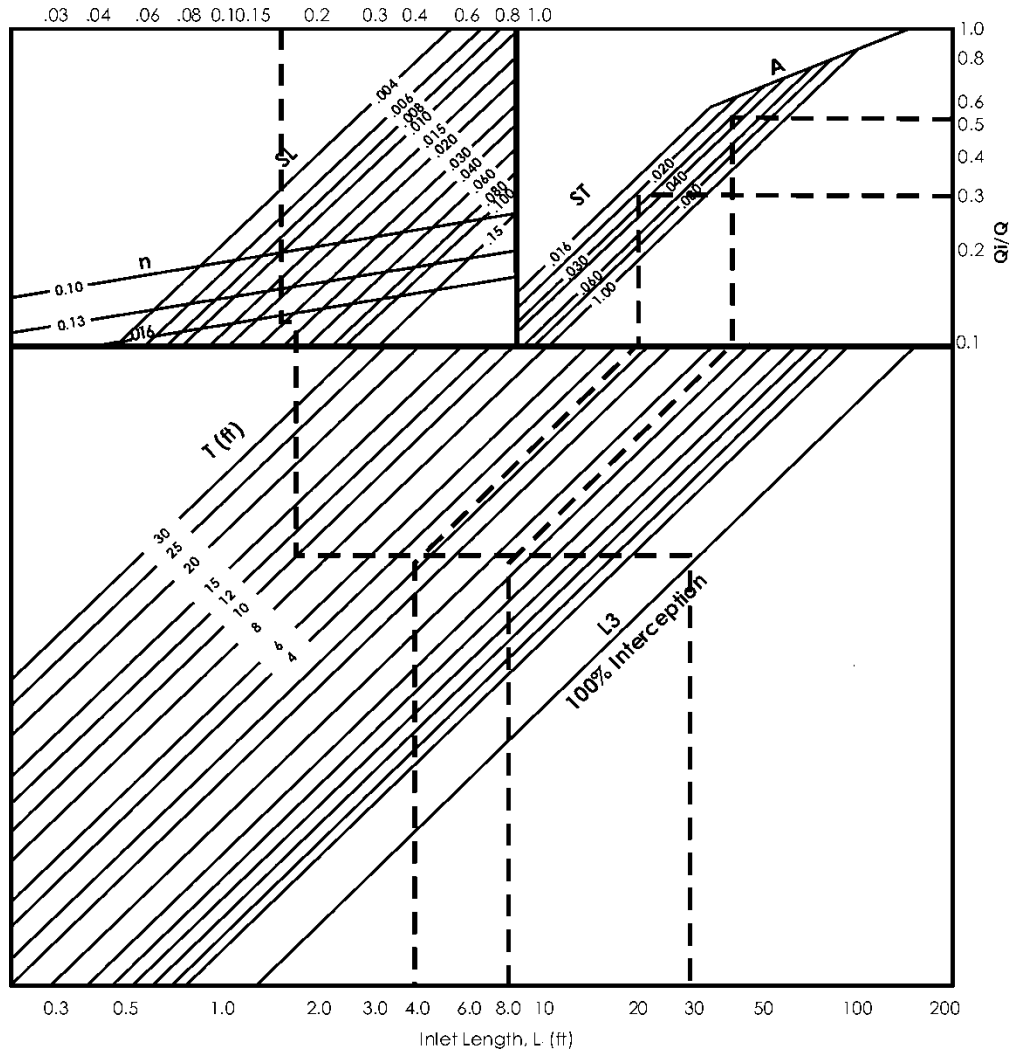

Figure 3: “K” Values for Standard Type SW-501, 502, 503, 504, 505, and 506 Intakes - Vane Grate and Curb Hood

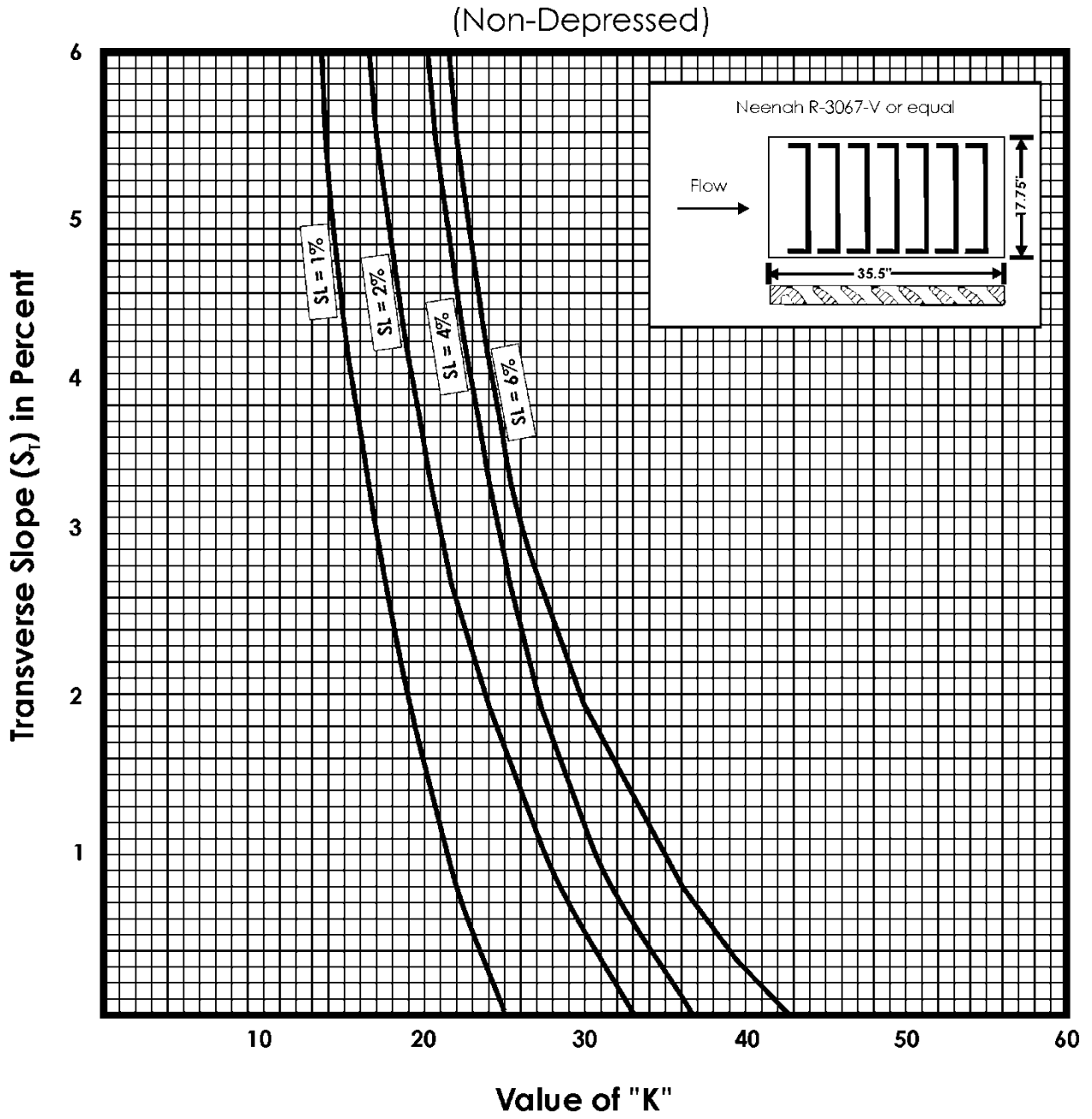

Figure 4: "K" Values for Driveway Grate Intake
(Non-Depressed)

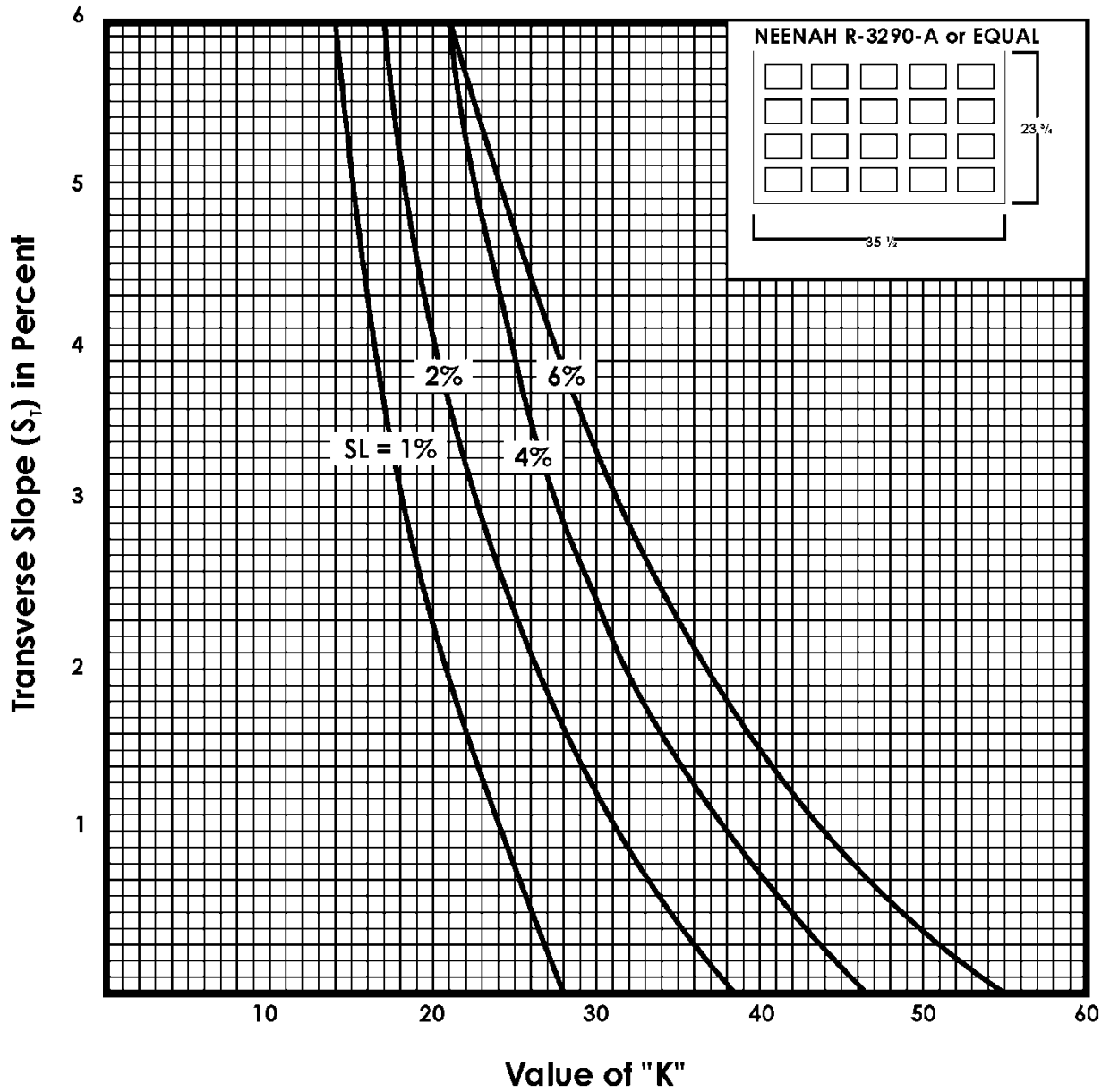
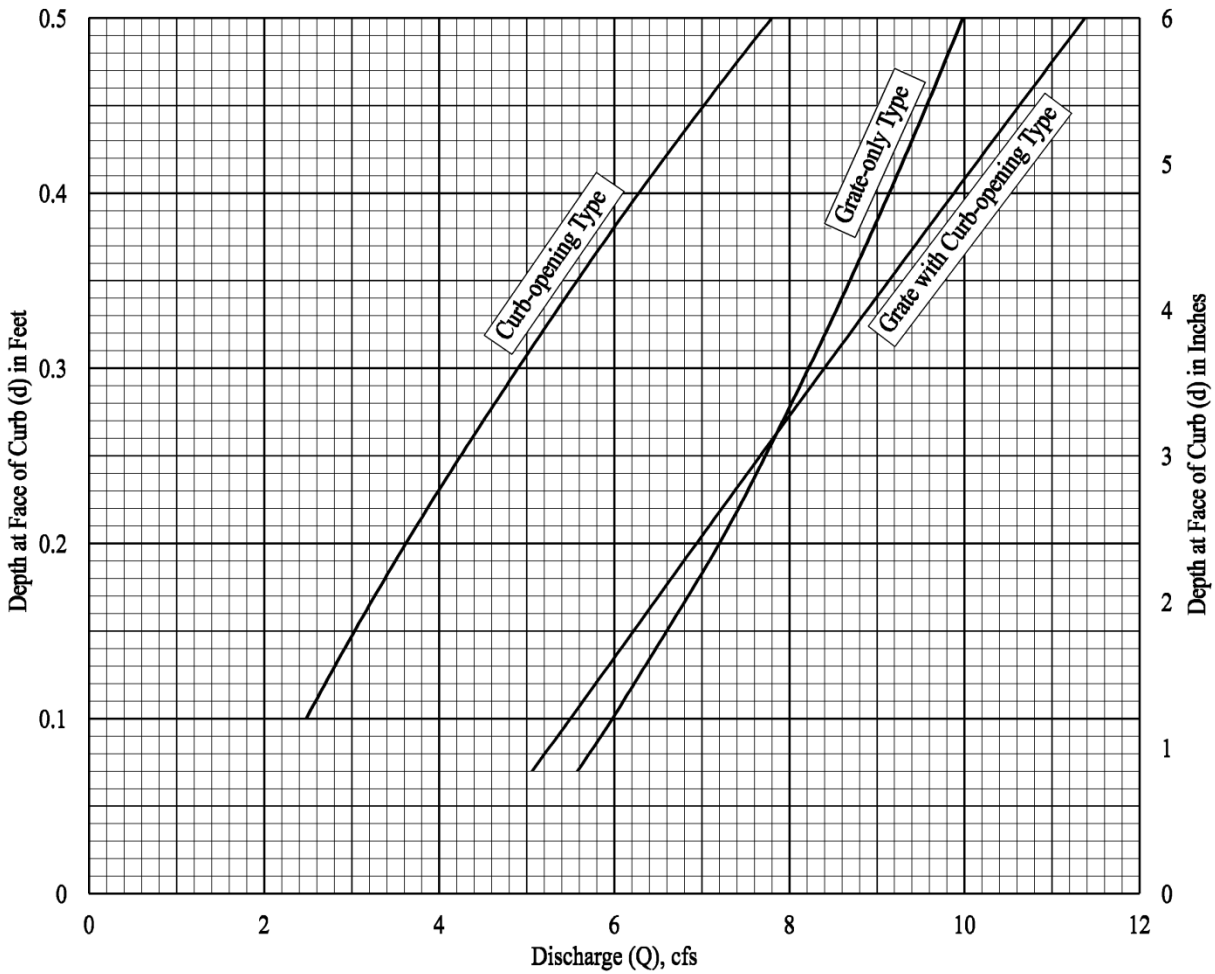

Figure 5: Capacity of Standard Single Type Intakes at a Low Point



Equations for above Curves

Curb-opening, Types SW-507, 508, 509, and 510

Grate with Curb-opening, Types SW-501, 502, 503, 504, 505, and 506

Grate only, Types SW-501 and 502 without curb hood

$$Q = 12h^{3/2}$$

$$Q = 8.44h^{1/2} + 8.25h^{3/2}$$

$$Q = 12.62h^{1/2}$$

where $h = d(\text{ft}) + A(\text{ft})$

A = 3" (0.25') for Curb-opening

A = 2" (0.167') for Grate with Curb-opening

A = 1.5" (0.125') for Grate only

Note: For double intakes, take the values calculated for single intakes times two.

Figure 6: Capacity of Curb Opening Intake at Low Point

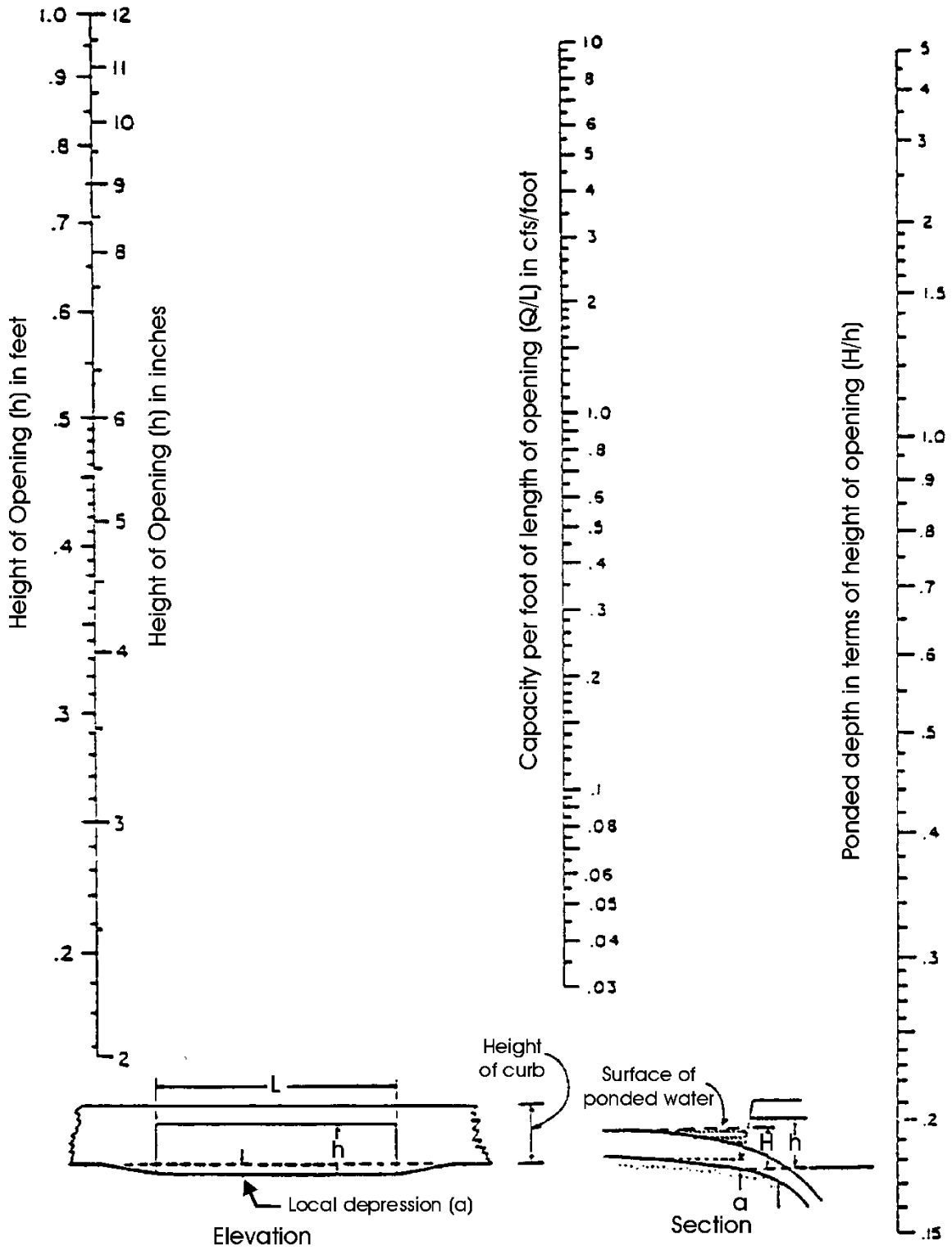

F. Manhole and intake standards

1. Manhole standards to be utilized:

Type	Description	Use	
		Main Pipe Size	Depth Restrictions
SW-401 Fig. 6010.401	Circular Storm Sewer Manhole	12" min. See table on Fig. 6010.401 for max. pipe size	N/A
SW-402 Fig. 6010.402	Rectangular Storm Sewer Manhole	12" to 54"	8' max.
SW-503 Fig. 6010.403	Deep Well Rectangular Storm Sewer Manhole	12" to 72"	12' max.
SW-404 Fig. 6010.404	Rectangular Base/Circular Top Storm Sewer Manhole	12" to 96"	12' min. - 22' max.
SW-405 Fig. 6010.405	Tee-section Storm Sewer Manhole	12" or greater	N/A

2. Manhole castings to be utilized:

Figure No. ¹	Casting Type	Number of Pieces	Ring/Cover	Bolted Frame	Bolted Cover (Floodable)	Gasket
6010.602	E	2	Fixed ²	Yes	No	No
6010.602	F	3	Adjustable ³	No	No	No
¹ The figure numbers listed in this table refer to figures from the SUDAS Standard Specifications.						
² Typically used with non-paved or flexible surfaces, including HMA, seal coat, gravel, and brick.						
³ Typically used with PCC surfaces, including castings in concrete boxouts.						

3. Intake standards to be utilized:

Intake Type	Intake Casting	Standard	Conditions
Curb-Grate SW-501	SW-603 Type Q	Single, poured 6" walls	Intake depth $\leq 7'$ Pipe size: 18" max. on 2' side, 30" max. on 3' side
Curb-Grate SW-502	SW-603 Type Q	Single, precast walls	Intake depth $> 7'$ Pipe size: 24" max. for 48" diameter
Curb-Grate (Combination) SW-503/SW-504	SW-603 Type Q	Single, poured 6" walls	Intake depth $\leq 6' 6''$ Pipe size: 30" max. on 3' side, 36" max. on 6' side
Curb-Grate SW-505	SW-603 Type Q	Double, poured 6" walls	Intake depth $\leq 7'$ Pipe size: 18" max. on 2' side, 66" max. on 6' 8" side
Curb-Grate (Combination) SW-506	SW-603 Type Q	Double, poured 6" walls	Intake depth $\leq 6' 6''$ Pipe size: 30" max. on 3' side, 36" max. on 6' side, 48" max. on 6' 8" side
Curb Only SW-507	N/A	Single open throat, poured 6" walls	Intake depth $\leq 10'$ Pipe size: 30" max. on 3' side, 36" max. on 4' side
Curb Only SW-508	N/A	Single open throat, poured 6" walls	Intake depth $\leq 16'$ Pipe size: 36" max.
Curb Only SW-509	N/A	Double open throat, poured 6" reinforced walls	Intake depth $\leq 10'$ Pipe size: 30" max. on 3' side, 66" max. on 8' side
Curb Only SW-510	N/A	Double open throat, poured 6" reinforced walls	Intake depth $< 10'$ Pipe size: 36" max. on 4' side, 66" max. on 8' side
Driveway or Alley Grate Intake SW-511	SW-604 Type 6	Single (Surface Intake) Poured 6" walls	Intake depth $\leq 7'$ Pipe size: 18" max. on 2' side, 30" max. on 3' side
Area Intake SW-512	SW-604 Type 3, 4, or 5	Precast, Area Intake	Intake depth $> 7'$ Pipe size varies on structure size
Ditch Intake SW-513	SW-602 Type E	Area Intake (side open intake) Poured 6" walls	Intake depth $\leq 7'$ Pipe size varies on structure size

4. Concrete poured walls are required for all other drainage structures. Cure time is required for poured wall intakes unless high early strength concrete is used, or concrete beams are taken. Upon approval of the Jurisdictional Engineer solid concrete block walls may be used on shallow structures when the depth from the gutter flowline to the pipe invert does not exceed 40 inches. Restrictions on the number of pipe connections and angle of entry may be imposed on solid concrete block intakes without combination manholes.

5. Combination Intakes may be required if utility locations and/or pipe size show a need for the manhole. Intakes with combined manholes will be used when the size of the connecting pipes so indicate or when horizontal clearance is necessary behind the back of curb. The Design Engineer is encouraged to place intakes combined with manholes for storm sewers that are parallel to the street. This will prevent storm sewers from being installed under pavement and thus improves future maintenance access without removing pavement. Approval will be required by the Jurisdictional Engineer when storm sewers or footing drains parallel to the street are placed under the pavement.

G. Intake capacity design example

1. **Capacity of gutter for straight crown.** Figure 1 is the nomograph used to determine the gutter capacity for a straight crown or segmented straight crown. Figure 1 can also be used to approximate the capacity of curved crowns.

- a. **Given:**

- 1) 26' B/B Street
- 2) $S_L = 4.0\%$
- 3) $S_T = 2.0\%$
- 4) $n = 0.016$
- 5) $Q = 2.5$ cfs

- b. **Find:**

- 1) d = depth of flow
- 2) T = spread of water from face of curb

- c. **Steps:** (Use Figure 1)

- 1) Calculate the value of "Z" which is the reciprocal of the transverse slope (S_T). $Z = 1/S_T = 1/0.020 = 50$.
- 2) Calculate the ratio $Z/n = 50/0.016 = 3125$.
- 3) Connect the Z/n ratio (3125) and the channel slope ($S_L = 4.0\%$) with a straight line. This will give a point of intersection on the turning line.
- 4) Connect this point and the discharge (2.5 cfs) with a straight line and read the depth at the face of curb ($d = 0.158$) in feet.
- 5) Calculate the value of the spread using the equation:
 $T = Zd$
 $T = 50 (0.158) = 7.9$ feet

2. **Capacity of grate with curb-opening type intake on a continuous grade.** The allowable capacity of an intake on a continuous grade will be determined by the following equation:

$$Q_I = K \left(d^{5/3} \right) (R_F)$$

Figure 3 is used to determine "K" for a vane grate and includes the curb hood. Figure 4 gives "K" for a driveway condition where no curb hood can be used. The appropriate reduction factor from Table 3 must then be applied to obtain the actual flow intercepted by the intake.

- a. **Given:** Street conditions as per “capacity of gutter for straight crown” example.

Design discharge	Q	= 145 cfs	[9]
Invert of pipe		= 94.50'	[2]
Starting water surface	W.S.	= 100'	[4]

Note: Number in brackets refers to the columns of Worksheet 2.

The pipe diameter needs to meet: 1) Low-flow cleaning velocity, 2) Slope for full flow, and 3) Surcharges in manhole or intake structures.

- b. **Find:** Flow intercepted by SW-501 Intake (Q_i)

c. **Steps:**

- 1) Enter Figure 3 with the transverse slope ($S_T = 2.0\%$)
- 2) Extend horizontally to the appropriate curve for the longitudinal slope ($S_L = 4.0\%$); extend vertically downward and read the value of "K" equal to 23.9. The reduction factor for standard intake on continuous grade is 90% (from Table 3).

$$Q_i = K \left(d^{5/3} \right) (R_F)$$

$$Q_i = 23.9 \left(0.158^{5/3} \right) (0.90) = 0.99 \text{ cfs}$$

3. **Capacity of curb opening intakes on a continuous grade.** Figure 2 is used to determine the interception ratio of the intake. This theoretical interception ratio (Q_i/Q) multiplied by the design flow in the gutter and the reduction factor equals the flow intercepted by the intake.

- a. **Given:** Street conditions as per “capacity of gutter for straight crown” example

- b. **Find:** Flow intercepted by SW-507 or SW-509 intake (Q_i)

c. **Steps:**

- 1) Enter Figure 2 at the top left hand edge with the depth of flow d_w ($d_w = S_T(T-2)$) (0.118 feet).
- 2) Follow vertically down to the line representing Manning’s n (0.016). Move horizontally across until intersecting the line representing the longitudinal slope, S_L (0.04). Follow vertically down to the flow spread, T (7.9 feet). Construct a horizontal line from this point.
- 3) Next, enter the chart from the bottom with the length of the inlet opening (4 feet for a standard SW-507 and 509 intake). Extend a line vertically from this point to the horizontal line constructed at the intersection with the flow spread (T). Move diagonally to the line formed at $Q_i/Q=0.1$. Extend a line vertically to S_T (0.02), or line A, and then horizontally to Q_i/Q (0.29).

$$Q_i = \left(\frac{Q_i}{Q} \right) (Q) (R_F)$$

$$Q_i = (0.29)(2.5)(0.9) = 0.653 \text{ cfs}$$

4. **Capacity of all intakes at a low point.** Figure 5 is used to determine the capacity Q of all intakes at a low point. The appropriate reduction factor from Table 3 must be applied to the results.

a. **Given:**

- 1) 26 feet B/B Street – Residential
- 2) $S = 2\%$ from East
- 3) $S = 1\%$ from West
- 4) $Q = 4.5$ cfs from East in each gutter
- 5) $Q = 6$ cfs from West in each gutter

b. **Find:** Q_I for Type SW-501 intake with vane grate

c. **Steps:**

- 1) Enter Figure 5 with d -max for 26 feet B/B street (6 inches). Extend vertically downward from the grate with curb opening curve and read the value of 11.4 cfs (or use equations provided).
 $Q_I = 11.4 (0.80) = 9.12$ cfs = Q_I maximum allowable.
- 2) Since Q_I is less than $Q_{total} = 4.5+6= 10.5$ cfs, additional intakes must be constructed to intercept flow so that flooding beyond the allowable limit does not occur.

5. **Capacity of SW-501 intakes at a low point**

a. **Given:** $Q_{total} = 9$ cfs

b. **Find:** d , if one SW-501 intake is built.

c. **Steps:**

- 1) Calculate the actual flow in the gutter (if the intake is partially clogged) so that the intake will intercept 10 cfs.

$$Q = \frac{Q_I}{R_F} = \frac{9.0}{0.80} = 11.25 \text{ cfs}$$

- 2) Use equations shown in Figure 5 (or use curves)

$$11.25 = 8.44 \left(H^{1/2} \right) + 8.25 \left(H^{3/2} \right) \text{ where } H = d + a$$

$$H = .66 \text{ ft.}$$

$$d = H - a = .66 - .17 = 0.49 \text{ ft.}$$

Figure 7: Pipe Standards at a Low Point for SW-501 Intake

(Unless otherwise approved by the Jurisdictional Engineer, the following pipe sizes and grades will be the minimum allowable at low points. (Based on $n = 0.013$)

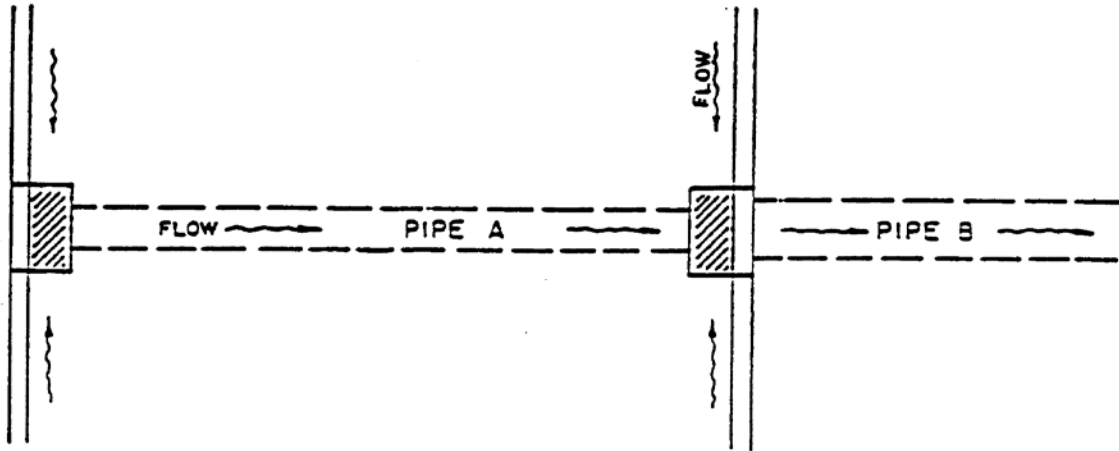

Minimum for Single Intakes

Pipe A	Pipe B
Q = 7.6 CFS	Q = 15.2 CFS
18" Pipe @ 1.0% (Minimum)	24" Pipe @ 0.46%
15" Pipe @ 1.5%	18" Pipe @ 2.23%
	15" Pipe @ 6.0%

Minimum Desirable for Single Intakes

Pipe A	Pipe B
Q = 11.8 CFS	Q = 23.6 CFS
18" Pipe @ 1.4%	24" @ 1.1%
15" Pipe @ 3.6%	18" @ 5.4%

Minimum for Double Intakes

Pipe A	Pipe B
Q = 15.2 CFS	Q = 30.4 CFS
24" Pipe @ 0.46%	30" Pipe @ 0.55%
18" Pipe @ 2.3%	24" Pipe @ 1.8%
15" Pipe @ 6.0%	18" Pipe @ 9.0%

