

2F-1 Sand Filter



BENEFITS			
	Low = <30%	Medium = 30-65%	High = 65-100%
	Low	Med	High
Suspended Solids			■
Nitrogen	■		
Phosphorous		■	
Metals		■	
Bacteriological		■	
Hydrocarbons		■	

Description: A sand filter is a multi-chamber structure designed to treat stormwater runoff through filtration, using a sediment forebay and a sand bed as its primary filter media. In some cases, a third chamber may be used to collect filtered runoff. Typically, an underdrain is used to return the filtered runoff to the conveyance system.

Typical uses: High-density/ultra-urban location where available land is restricted, such as a receiving area for runoff from an impervious site.

Advantages/benefits:

- Stormwater filters have their greatest applicability for small development sites – drainage areas of up to 5 surface acres.
- Good for highly impervious areas.
- Good retrofit capability.
- Good for areas with extremely limited space.
- Can provide runoff quality control, especially for smaller storms; generally provide reliable rates of pollutant removal through careful design and regular maintenance.
- No restrictions on soils at installation site if filtered runoff is returned to the conveyance system.

Disadvantages/limitations:

- High maintenance burden.
- Not recommended for areas with high sediment content in stormwater or areas receiving significant clay/silt runoff.
- Relatively costly.
- Possible odor problems.
- Porous soil required at site, if filtered runoff is to be exfiltrated back into the soil.
- Not recommended for residential developments due to higher maintenance burden.

Maintenance requirements:

- Inspect for clogging – rake first inch of sand.
- Remove sediment from forebay/chamber.
- Replace sand filter media as needed.

A. Description

Sand filters are structural stormwater controls that capture and temporarily store stormwater runoff and pass it through a filter bed of sand. Most sand filter systems consist of two or three chambered structures. The first chamber is a sediment forebay or sedimentation chamber, which removes floatables and heavy sediments. The second is the main filtration chamber, which removes additional pollutants by filtering the runoff through a sand bed. A third chamber is sometimes utilized to collect the filtered runoff. The filtered runoff is typically returned to the conveyance system by an underdrain, though it can also be partially or fully exfiltrated into the surrounding soil in areas with porous soils. Because they have few site constraints besides head requirements, sand filters can be used on development sites where the use of other structural controls may be precluded. However, sand filter systems can be relatively expensive to construct and install.

There are three sand filter system design variants: the surface sand filter, perimeter sand filter, and underground sand filter. Descriptions of these filter systems are provided below:

1. **Surface sand filter.** The surface sand filter is a ground-level open-air surface structure that consists of a pre-treatment sediment forebay and a filter bed chamber (Figures 1 and 2). This system is typically used to treat drainage areas 2-10 acres in size and is typically located off-line. Surface sand filters can be designed as an excavation with earthen embankments or as a concrete or block structure. A flow splitter is used to divert the first flush of runoff into an off-line sedimentation chamber. The chamber may be either wet or dry, and is used for pre-treatment. Coarse sediments drop out as the runoff velocities are reduced. Runoff is then distributed into the second chamber, which consists of 18-24-inch deep sand filter bed and temporary runoff storage above the bed. Pollutants are trapped or strained out at the surface of the filter bed. The filter bed surface may have optional sand or grass cover. A series of perforated pipes located in a gravel bed collect the runoff passing through the filter bed, and return it into the stream or channel at a downstream point. If underlying soils are permeable, and groundwater contamination unlikely, the bottom of the filter bed may have no lining, and all or part of the filtered runoff may be allowed to exfiltrate into the soil.
2. **Perimeter sand filter.** The perimeter sand filter is an enclosed filter system typically constructed just below grade in a vault along the edge of an impervious area such as a parking lot (Figure 3). First developed by Shaver and Baldwin (1991), the system consists of two parallel trench-like chambers installed along the perimeter of a parking lot. This system is usually used to treat drainage areas up to 2 acres in size, and consists of a sedimentation chamber and a sand bed filter. Runoff flows into the first chamber through a series of inlet grates located along the top of the control. The first trench provides pre-treatment through sedimentation in a shallow permanent pool of water before the runoff spills into the second trench, which consists of an 18-inch deep sand layer. During a storm event, runoff is temporarily detained above the normal pool and sand layer. When both chambers fill up to capacity, excess parking lot runoff is routed to a bypass drop inlet. The remaining runoff is filtered through the sand, collected by underdrain piping, and delivered to a protected outflow point.
3. **Underground sand filter.** The underground sand filter is intended primarily for extremely space-limited and high-density areas. In this design, the sand filter is placed in a three-chamber underground vault (either on-line or off-line) accessible by manholes or grate openings (Figure 4). The initial chamber, a sedimentation (pre-treatment) chamber, temporarily stores runoff and utilizes a wet pool to capture sediment. The sedimentation chamber is connected to the sand filter chamber by a submerged wall that protects the filter bed from oil and debris. The filter bed is 18-24 inches deep and may have a protective screen of gravel or permeable geotextile to limit clogging. During a storm, the water quality volume (WQv) is temporarily stored in both the first

and second chambers. Flows in excess of the filter's capacity are diverted through an overflow weir. The sand filter chamber also includes an underdrain system with inspection and cleanout wells. Perforated drain piping under the sand filter bed extends into a third chamber that collects filtered runoff.

Figure 1: Surface sand filter (earthen structure)

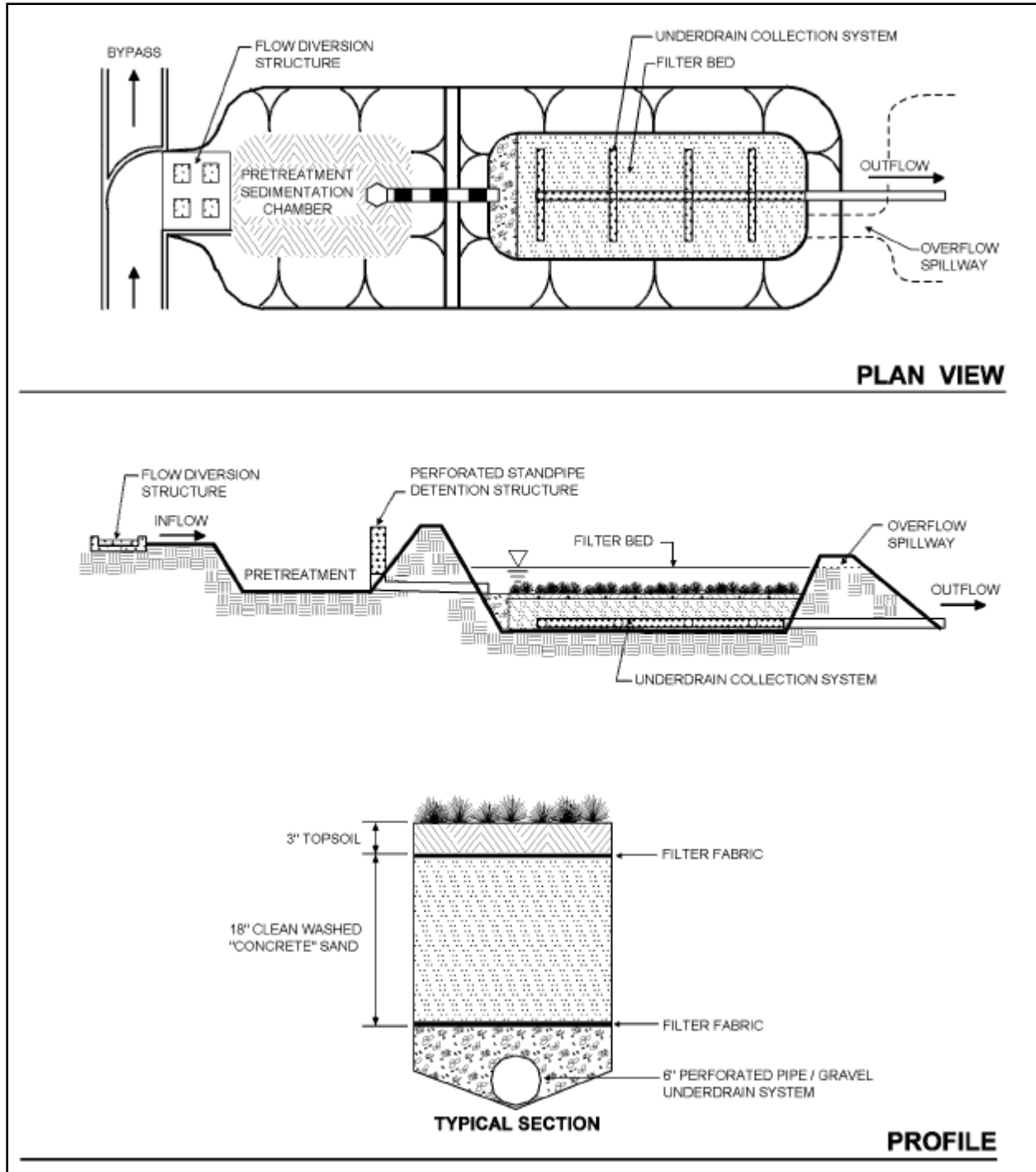

Source: Adapted from Claytor & Schueler, CWP, 1996

Figure 2: Surface sand filter (concrete structure)

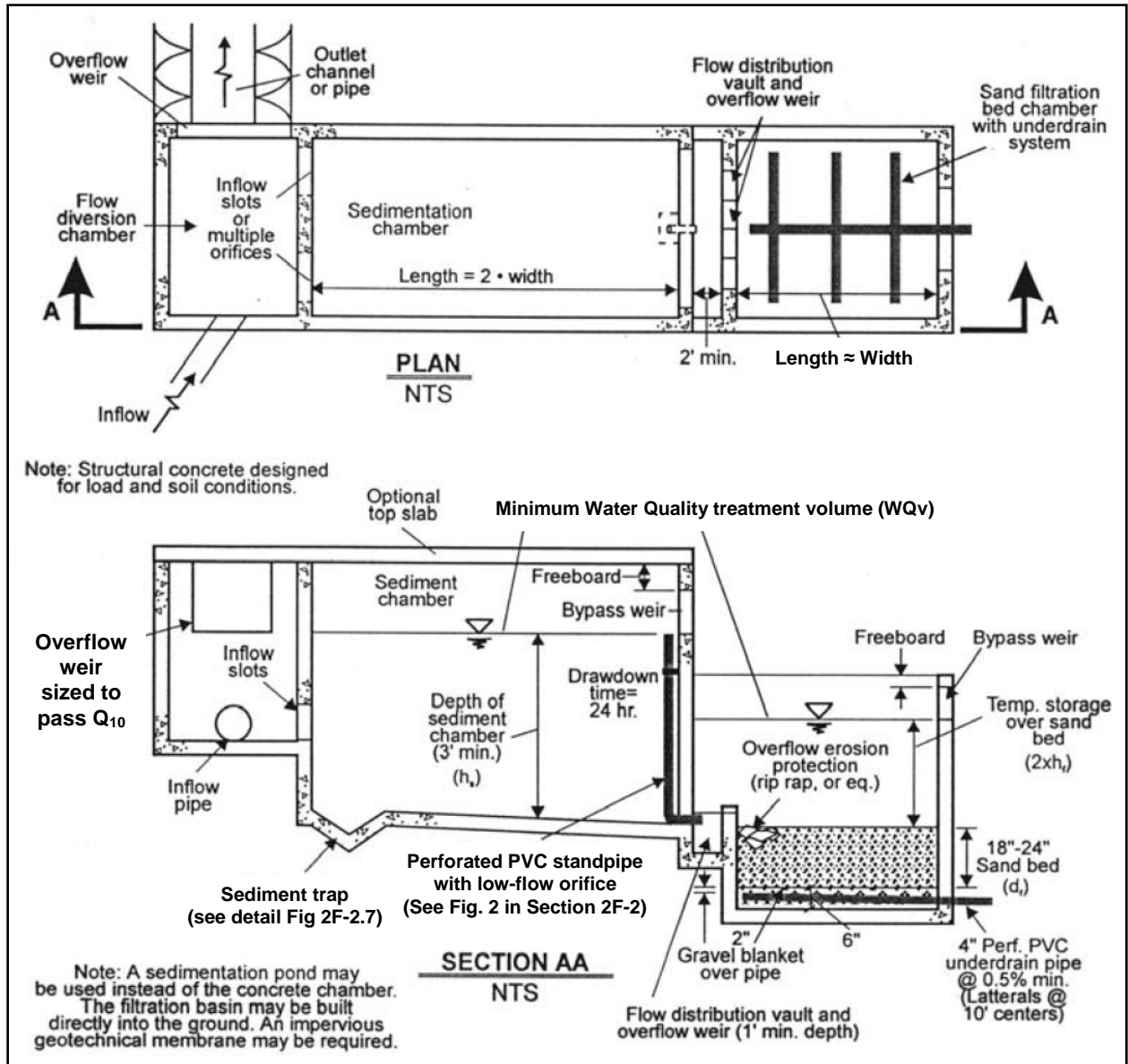

Source: Adapted from Claytor & Schueler, CWP, 1996

Figure 3: Perimeter sand filter

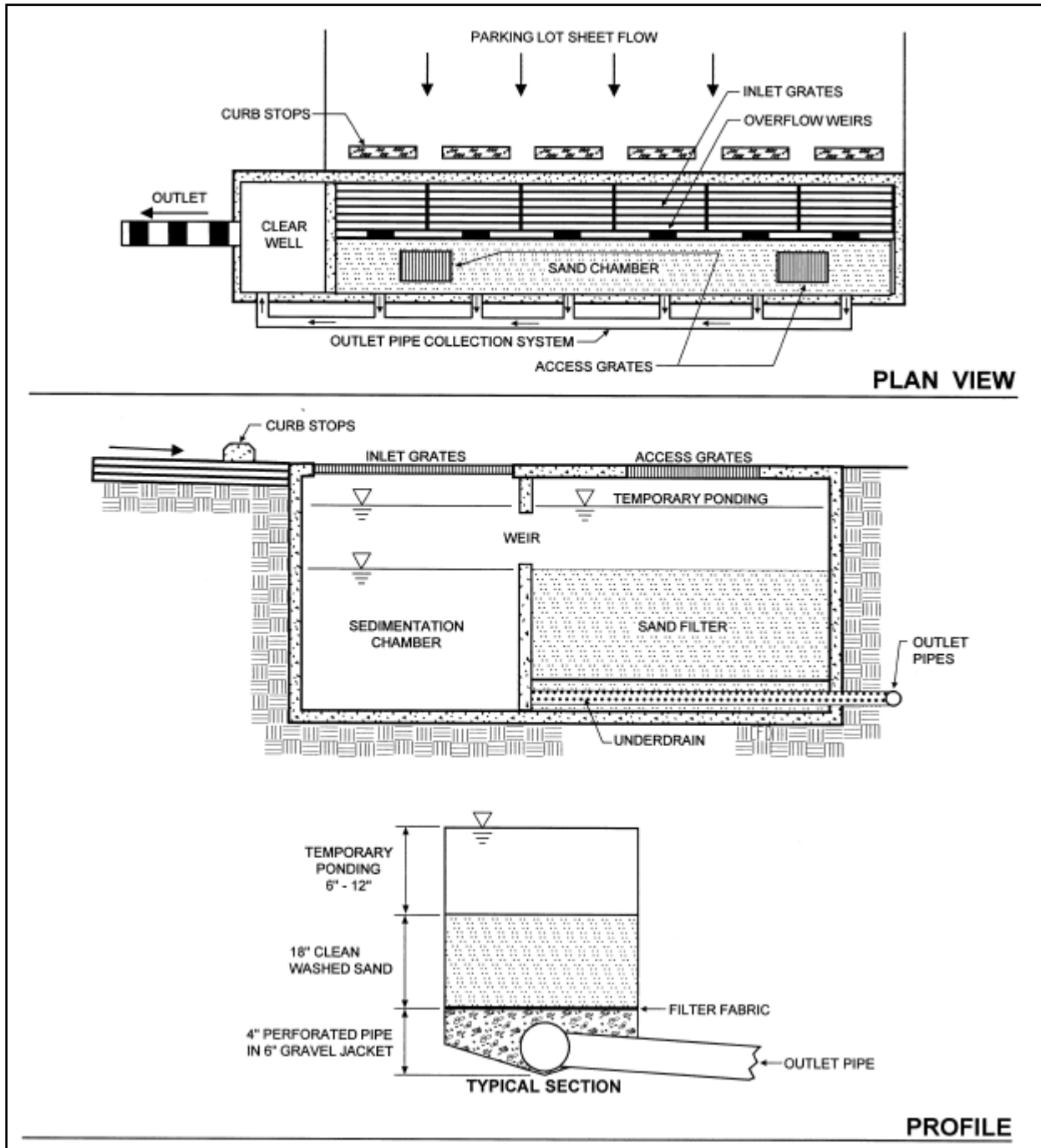

Source: Adapted from Claytor & Schueler, CWP, 1996

Figure 4: Underground sand filter

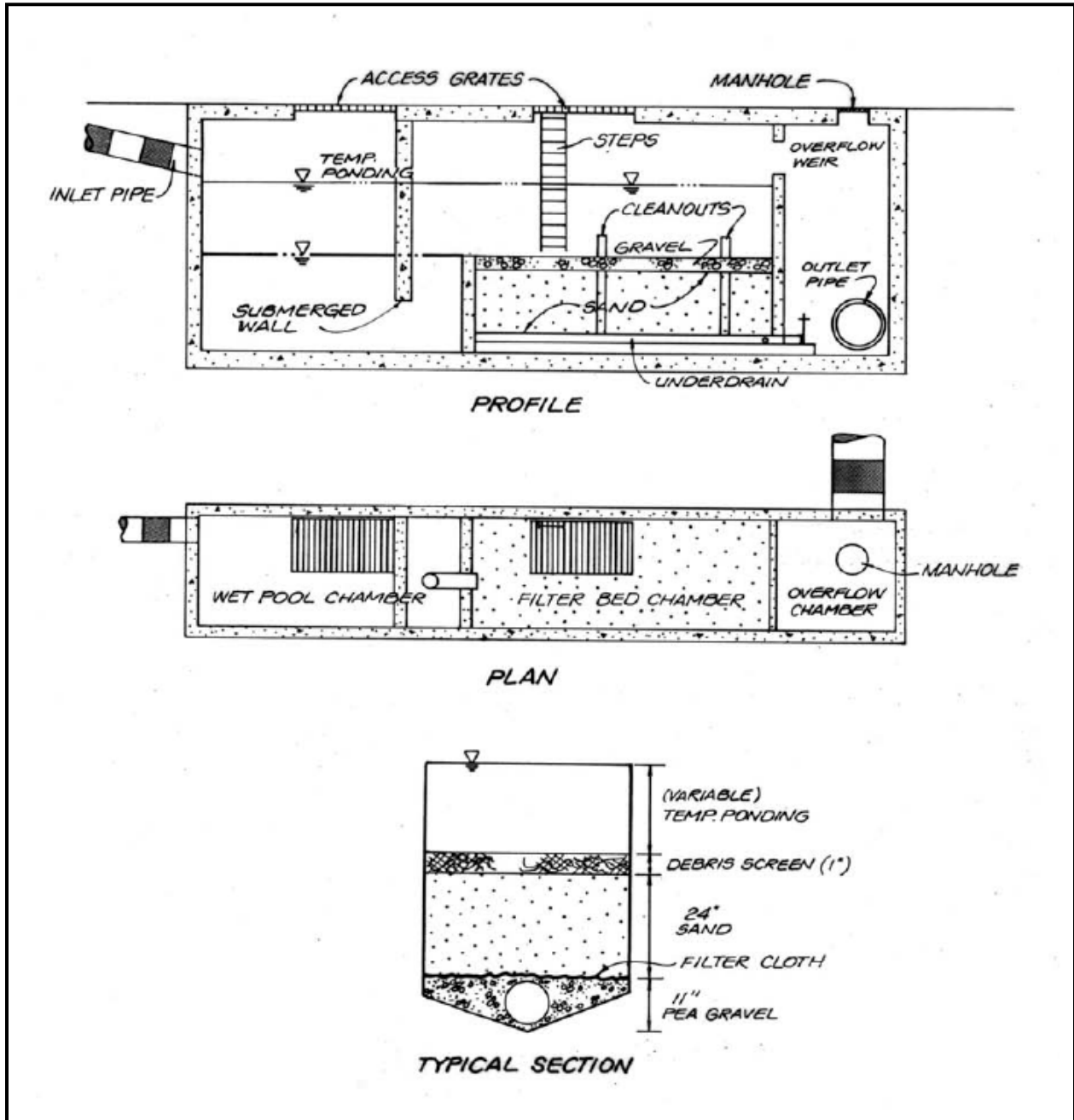

Source: Adapted from Claytor & Schueler, CWP, 1996

Figure 5: Surface sand filter**Figure 6:** Perimeter sand filter

B. Stormwater management suitability

Sand filter systems are designed primarily as off-line systems for stormwater quality (i.e., the removal of stormwater pollutants) and will typically need to be used in conjunction with another structural control to provide downstream channel protection, overbank flood protection, and extreme flood protection, if required. However, under certain circumstances, filters can provide limited runoff quantity control, particularly for smaller storm events.

1. **Water quality.** In sand filter systems, stormwater pollutants are removed through a combination of gravitational settling, filtration, and adsorption. The filtration process effectively removes suspended solids and particulates, biochemical oxygen demand (BOD), fecal coliform bacteria, and other pollutants. Surface sand filters with a grass cover have additional opportunities for bacterial decomposition, as well as vegetation uptake of pollutants, particularly nutrients. See Pollutant Removal Capabilities for planning and design purposes.
2. **Channel protection.** For smaller sites, a sand filter may be designed to capture the entire channel protection volume, CPV, in either an off-line or on-line configuration. Given that a sand filter system is typically designed to completely drain over 40 hours, the requirement of extended detention of the 1-year, 24-hour storm runoff volume will be met. For larger sites or where only the WQv is diverted to the sand filter facility, another structural control must be used to provide Cpv extended detention.
3. **Overbank flood protection.** Another structural control must be used in conjunction with a sand filter system to reduce the post-development peak flow of the 25-year storm (Q_p) to pre-development levels (detention).
4. **Extreme flood protection.** Sand filter facilities must provide flow diversion and/or be designed to safely pass extreme storm flows and protect the filter bed and facility.

C. Pollutant removal capabilities

The following design pollutant removal rates are conservative average pollutant reduction percentages for design purposes derived from sampling data, modeling, and professional judgment. In a situation where a removal rate is not deemed sufficient, additional controls may be put in place at the given site in a series or treatment train approach.

- Total suspended solids – 80%
- Total phosphorous – 50%
- Total nitrogen – 25%
- Fecal coliform – 40%
- Heavy metals – 50%

D. Application and feasibility

1. General feasibility.

- a. Suitable for Residential Subdivision Usage – no
- b. Suitable for High Density/Ultra Urban Areas – yes
- c. Regional Stormwater Control – no

2. Physical feasibility – physical constraints at project site.

- a. **Drainage area.** 10 acres maximum for surface sand filter; 2 acres maximum for perimeter sand filter.
- b. **Space required.** Function of available head at site.
- c. **Site slope.** No more than 6% slope across filter location.
- d. **Minimum head.** Elevation difference needed at a site from the inflow to the outflow: 5 feet for surface sand filters; 2-3 feet for perimeter sand filters.
- e. **Minimum depth to water table.** For a surface sand filter with exfiltration (earthen structure), 2 feet are required between the bottom of the sand filter and the elevation of the seasonally high water table.
- f. **Soils.** No restrictions; Group A soils generally required to allow exfiltration (for surface sand filter earthen structure).
- g. **Other constraints/considerations.** Aquifer protection: do not allow exfiltration of filtered hotspot runoff into groundwater.

E. Planning and design criteria

The following criteria are to be considered minimum standards for the design of a sand filter facility:

1. **Application and site feasibility criteria.** Sand filter systems are well-suited for highly impervious areas where land available for structural controls is limited. Sand filters should primarily be considered for new construction or retrofit opportunities for commercial, industrial, and institutional areas where the sediment load is relatively low, such as parking lots, parking ramps, driveways, loading docks, gas stations, garages, airport runways/taxiways, and storage yards. Sand filters may also be feasible and appropriate in some multi-family or higher density residential developments.
2. **Initial selection criteria.**
 - a. Is the filter appropriate for the type of development being considered?
 - b. Do site conditions such as space consumption, available head, cost, or maintenance consideration favor the use of the proposed design?
 - c. How effective is the stormwater filter design in removing the key pollutants of concern?

The following physical constraints should be evaluated to ensure the suitability of a sand filter facility for meeting stormwater management objectives on a site or development:

3. **Location and siting.**
 - a. Surface sand filters should have a contributing drainage area of 10 acres or less. The maximum drainage area for a perimeter sand filter is 2 acres.
 - b. **Minimum head.** Elevation difference needed at a site from the inflow to the outflow: 5 feet for surface sand filters; 2-3 feet for perimeter sand filters.
 - c. **Minimum depth to water table.** For a surface sand filter with exfiltration (earthen structure), 2 feet are required between the bottom of the sand filter and the elevation of the seasonally high water table.
 - d. **Soils.** No restrictions; HSG A soils generally required to allow exfiltration (for surface sand filter earthen structure)
 - e. **Pre-treatment.** Any disturbed areas within the sand filter facility drainage area should be identified and stabilized. Sites with less than 50% imperviousness or high clay/silt sediment loads must not use a sand filter without adequate pre-treatment due to potential clogging and failure of the filter bed. Filtration controls should only be constructed after the construction site is stabilized.
 - f. **Hydraulic loading.**
 - 1) **Quantity.** Surface sand filters are generally used in an off-line configuration where water is diverted to the filter facility through the use of a flow diversion structure and flow splitter. Likewise, flow greater than the capacity of the surface sand filter is diverted to other controls or downstream using a flow diversion structure or flow splitter.

- 2) **Flow pattern.** Sand filter systems are designed for intermittent flow and must be allowed to drain and re-aerate between rainfall events. They should not be used on sites with a continuous flow from groundwater, sump pumps, or other sources.
- g. Perimeter sand filters are typically sited along the edge, or perimeter, of an impervious area such as a parking lot.

F. Flow regulation

1. Since sand filters are designed to provide treatment for the WQv only, they should be located off-line from the primary conveyance/detention system.
2. Sand filters should be located where they can intercept as much of the site impervious area as possible and where discharge to the primary conveyance system is feasible.
3. Off-line designs are recommended for sand filter systems to avoid mixing with larger storm events which are likely to re-suspend settled solids within the sedimentation chamber, scour the filter bed, or otherwise compromise the pollutant removal effectiveness of these facilities.
4. The design objective is to capture and divert the WQv to the sand filter and bypass larger storms to the downstream storm drainage system or receiving water. WQv is computed based on the methods identified in Parts 2B and 2C.
5. In most Iowa jurisdictions, the enclosed conveyance systems are sized for the 5-10 year storm event. Open channel systems may be sized for larger events. A flow diversion structure must be able to accommodate these larger flows as well as the water quality storm.
6. Two methods for diverting the WQv include computing a peak discharge (Q_p) for the water quality storm (See Section 2C-7), and
 - a. Using an isolation/diversion structure upstream and within the drainage network as shown in Figure 7.
 - b. Incorporating the isolation/diversion structure within the treatment practice itself as shown in Figure 6.
7. The preferred method for accomplishing a diversion is within the treatment practice itself, where the overflow (or bypass) weir elevation is set equal to the design WQv elevation within the adjacent practice. This method ensures larger inflows will overflow the bypass weir, thus minimizing mixing within the BMP. It is also a more reliable capture technique than reliance on computed Q_p to size the diversion structure.
8. It is still necessary to compute the Q_p to size the intake slots or openings. The openings directing runoff to the treatment practice should be slightly oversized to ensure that the entire WQv is treated.
9. In many cases, however, it is not possible to maintain the necessary geometry and elevations to locate the isolation/diversion structure within the treatment practice itself. An alternative technique for isolation/diversion within the drainage network is described in Table 1.

Table 1: Design procedures for diversion of WQv within the drainage network

STEPS	CALCULATION
1	Peak discharge (Q_p) for WQv is computed based on the methods presented in Parts 2B and 2C.
2	Q_p for the bypass storm is computed (most jurisdictions use the 10-year frequency storm). Use the Rational Formula or NRCS WinTR-55.
3	Size diversion slots/openings or pipe utilizing the orifice equation: $Q = CA(2gh)^{0.5}$
4	Size overflow weir for bypass storm using the weir equation: $Q = CLh^{3/2}$ Size the outfall pipe, if provided, using the orifice equation (to check inlet condition flow capacity) and Manning's equation to check friction losses.

Source: Claytor and Schuler, 1996

Figure 7: Isolation/diversion structure

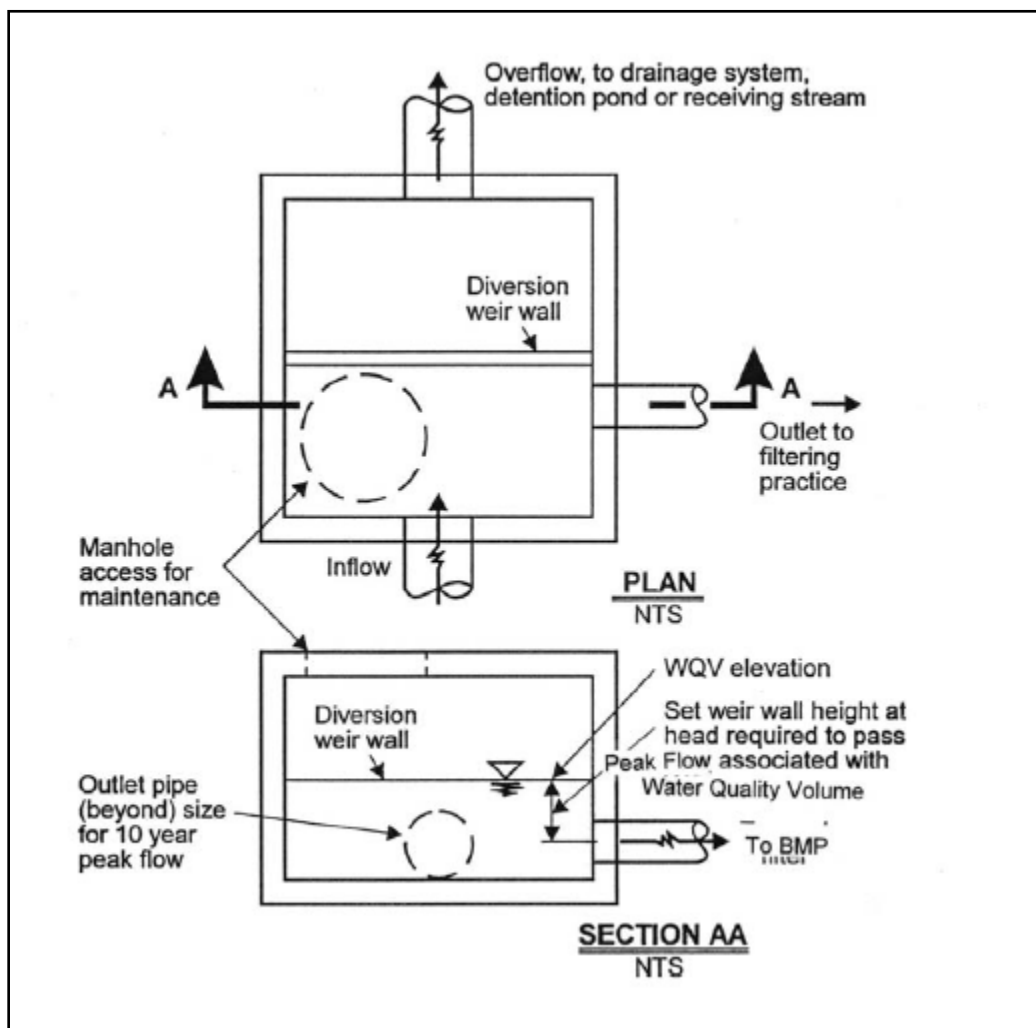

Source: Claytor and Schueler, 1996

2F-2 Design of Surface and Perimeter Sand Filter

A. Physical specifications and geometry

1. Surface sand filter.

- a. The entire treatment system (including the sedimentation chamber) must temporarily hold at least 75% of the WQv prior to filtration. Figure 1 illustrates the distribution of the treatment volume (0.75 WQv) among the various components of the surface sand filter, including:
- 1) V_s – volume within the sedimentation basin
 - 2) V_f – volume within the voids in the filter bed
 - 3) V_{f-temp} – temporary volume stored above the filter bed
 - 4) A_s – the surface area of the sedimentation basin
 - 5) A_f – surface area of the filter media
 - 6) h_s – height of water in the sedimentation basin
 - 7) h_f – average height of water above the filter media
 - 8) d_f – depth of filter media

Figure 1: Surface sand filter volumes

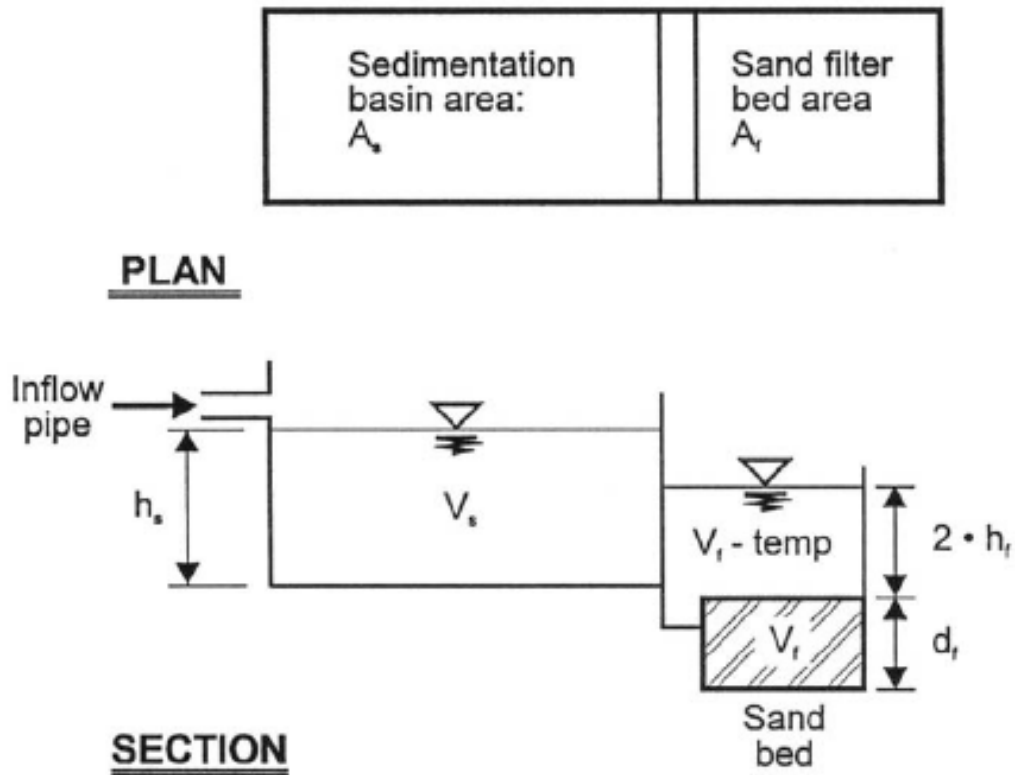

Source: Claytor and Schueler, 1996

- b. The basin bottom should be nearly level to facilitate sedimentation.

- c. Figure 2 shows a typical inlet pipe from the sedimentation chamber to the filter media basin for a surface sand filter.
- d. The filter area is sized based on the principles of Darcy's Law. A coefficient of permeability (k) of 3.5 ft/day for sand should be used. The filter bed is typically designed to completely drain in 40 hours or less.

Figure 2: Surface sand filter perforated inlet standpipe

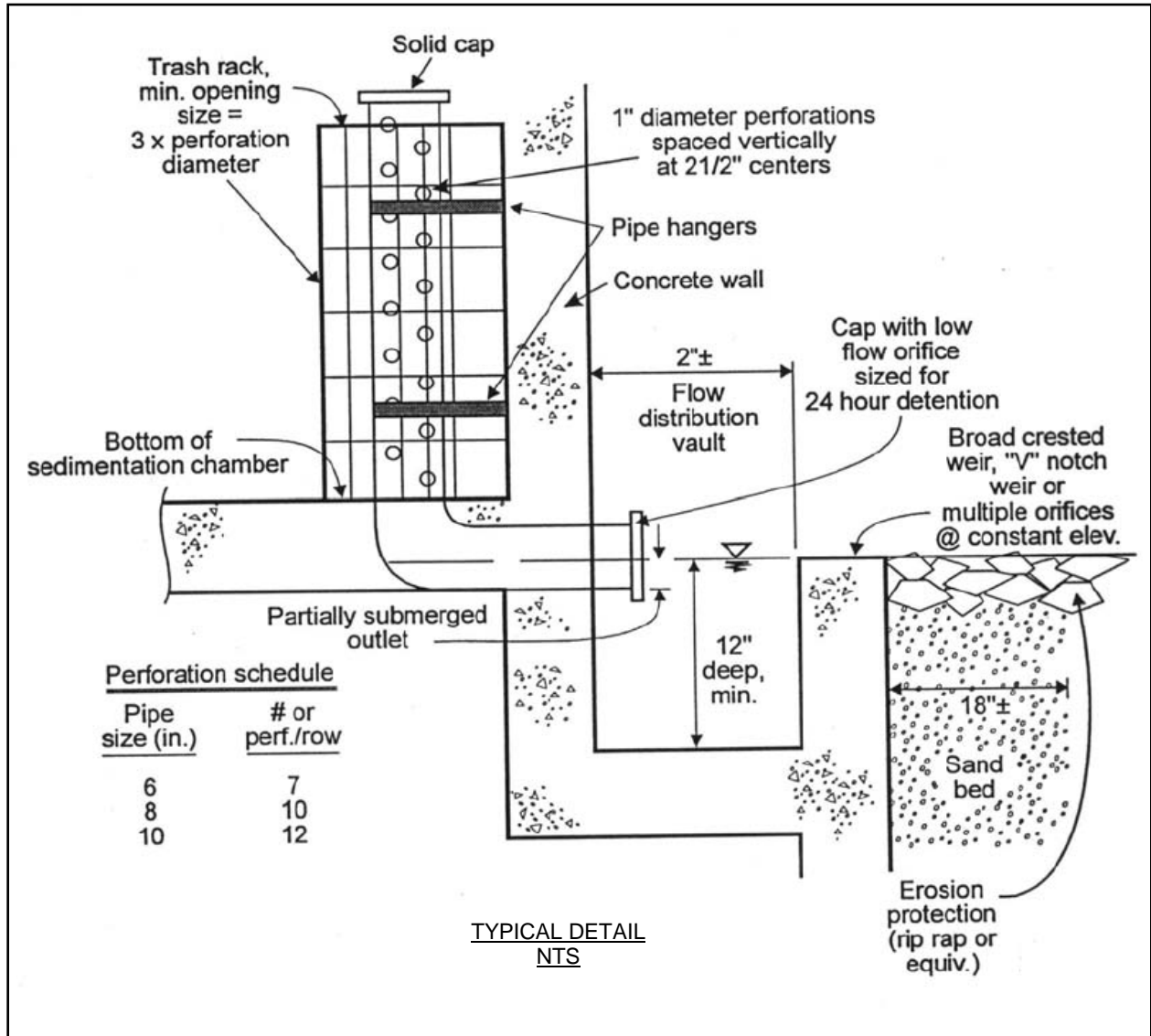

Source: Claytor and Schueler, 1996

- e. The filter media consists of an 18-inch layer of clean washed medium sand (meeting ASTM C-33 concrete sand or Iowa DOT Fine Aggregate Size No. 10) on top of the underdrain system. A typical sand media gradation is shown in Table 1.
- f. Three inches of topsoil are placed over the sand bed. Permeable filter fabric is placed both above and below the sand bed to prevent clogging of the sand filter and the underdrain system. Figure 3 illustrates a typical media cross section.

Table 1: Sand medium specification

U.S. Sieve Number	% Passing
4	95-100
8	70-100
16	40-90
30	25-75
50	2-25
100	<4
200	<2

Figure 3: Typical sand filter media cross sections

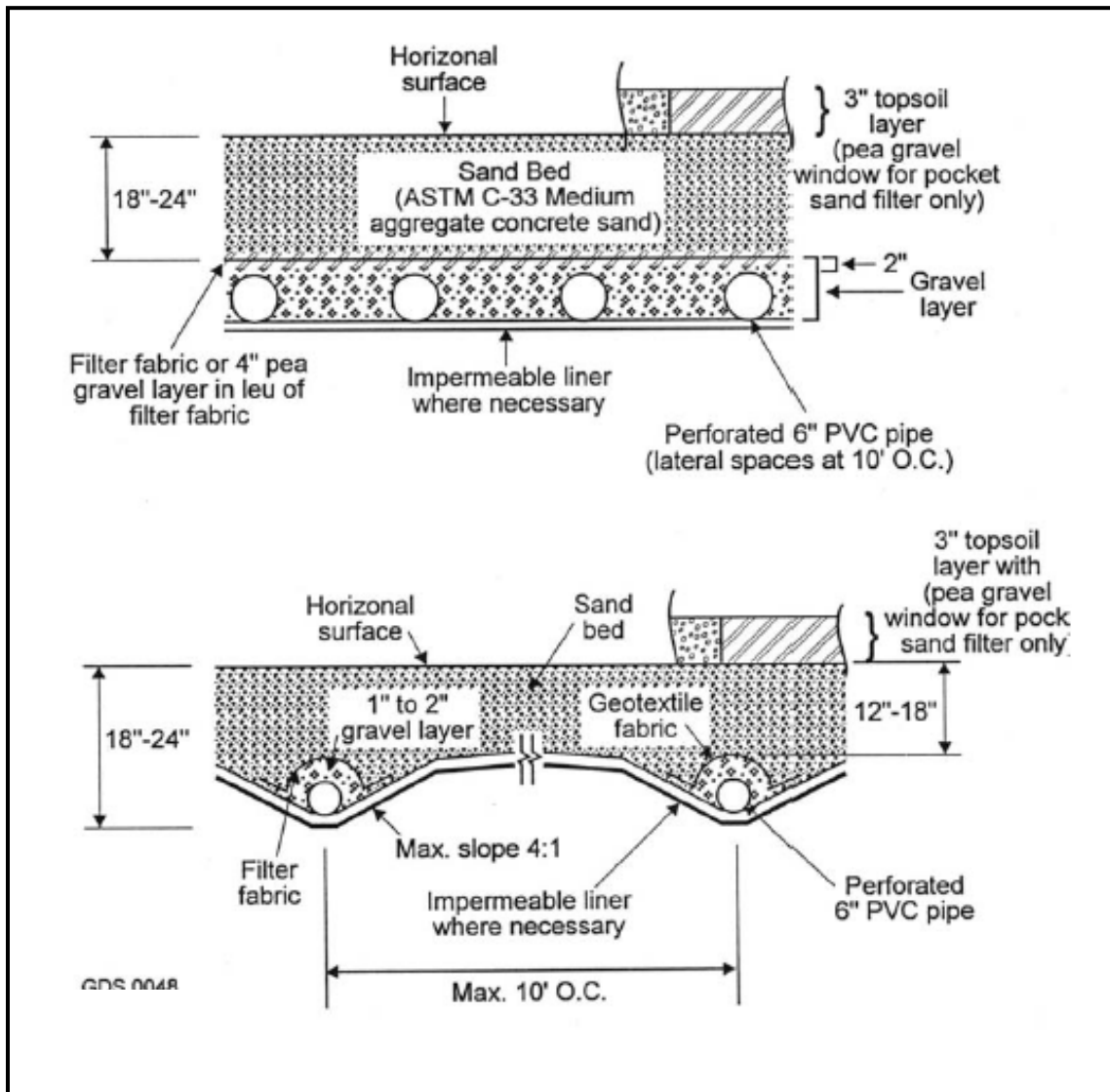

Source: Claytor and Schueler, 1996

- g. The filter bed is equipped with a 6-inch perforated PVC pipe (AASHTO M252) underdrain in a gravel layer. The underdrain must have a minimum grade of 1/8 inch per foot (1% slope). Holes should be 3/8-inch diameter and spaced approximately 6 inches on center. Gravel should be clean washed aggregate with a maximum diameter of 3.5 inches, a minimum diameter of 1.5 inches, and a void space of about 40% (Iowa DOT No. 3 stone). Aggregate contaminated with soil shall not be used.
- h. The structure of the surface sand filter may be constructed of impermeable media such as concrete, or through the use of excavations and earthen embankments. When constructed with earthen walls/embankments, filter fabric should be used to line the bottom and side slopes of the structures before installation of the underdrain system and filter media.

2. Perimeter sand filter.

- a. The entire treatment system (including the sedimentation chamber) must temporarily hold at least 75% of the WQv prior to filtration. Figure 4 illustrates the distribution of the treatment volume (0.75 WQv) among the various components of the perimeter sand filter, including:
 - 1) V_w – wet pool volume within the sedimentation basin
 - 2) V_f – volume within the voids in the filter bed
 - 3) V_{f-temp} – temporary volume stored above the filter bed
 - 4) A_s – the surface area of the sedimentation basin
 - 5) A_f – surface area of the filter media
 - 6) h_f – average height of water above the filter media (1/2 htemp)
 - 7) d_f – depth of filter media
- b. The sedimentation chamber is sized to at least 50% of the computed WQv.
- c. The filter area is sized based on the principles of Darcy's Law. A coefficient of permeability (k) of 3.5 feet per day for sand should be used. The filter bed is typically designed to completely drain in 40 hours or less.
- d. The filter media consists of a 12- to 18-inch layer of clean washed medium sand (meeting ASTM C-33 concrete sand or Iowa DOT Fine Aggregate Size No. 10) on top of the underdrain system. Figure 3 illustrates a typical media cross section.
- e. The perimeter sand filter is equipped with a 4-inch perforated PVC pipe (AASHTO M 252) underdrain in a gravel layer. The underdrain must have a minimum grade of 1/8 inch per foot (1% slope). Holes should be 3/8-inch diameter and spaced approximately 6 inches on center. A permeable filter fabric is placed between the gravel layer and the filter media. Gravel is a clean washed aggregate with a maximum diameter of 3.5 inches, a minimum diameter of 1.5 inches, and a void space of about 40% (Iowa DOT No. 3 stone). Aggregate contaminated with soil shall not be used.

Figure 4: Perimeter sand filter volumes

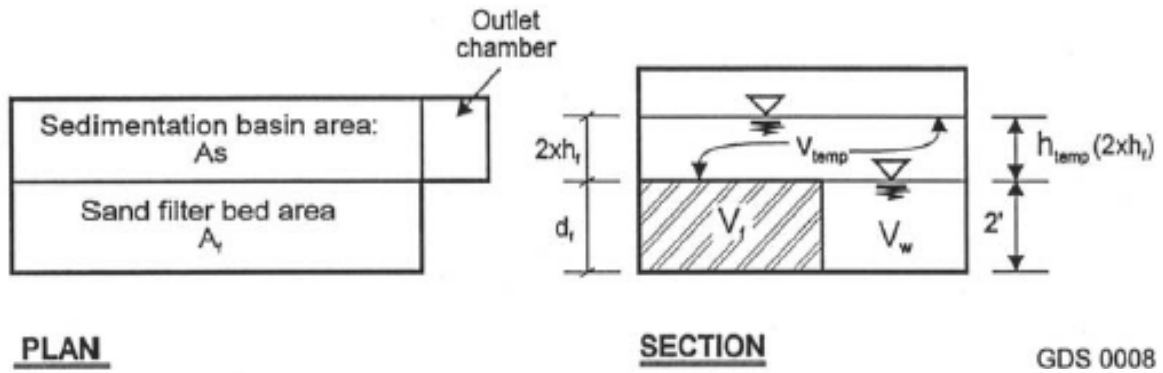

Source: Claytor and Schueler, 1996

B. Pre-treatment/inlets

1. Pre-treatment of runoff in a sand filter system is provided by the sedimentation chamber.
2. Inlets to surface sand filters should be provided with energy dissipators. Exit velocities from the sedimentation chamber must be non-erosive.
3. Figures 2 and 5 show typical inlet configurations from the sedimentation basin to the filter media basin for the surface sand filter.

Figure 5: Perimeter sand filter

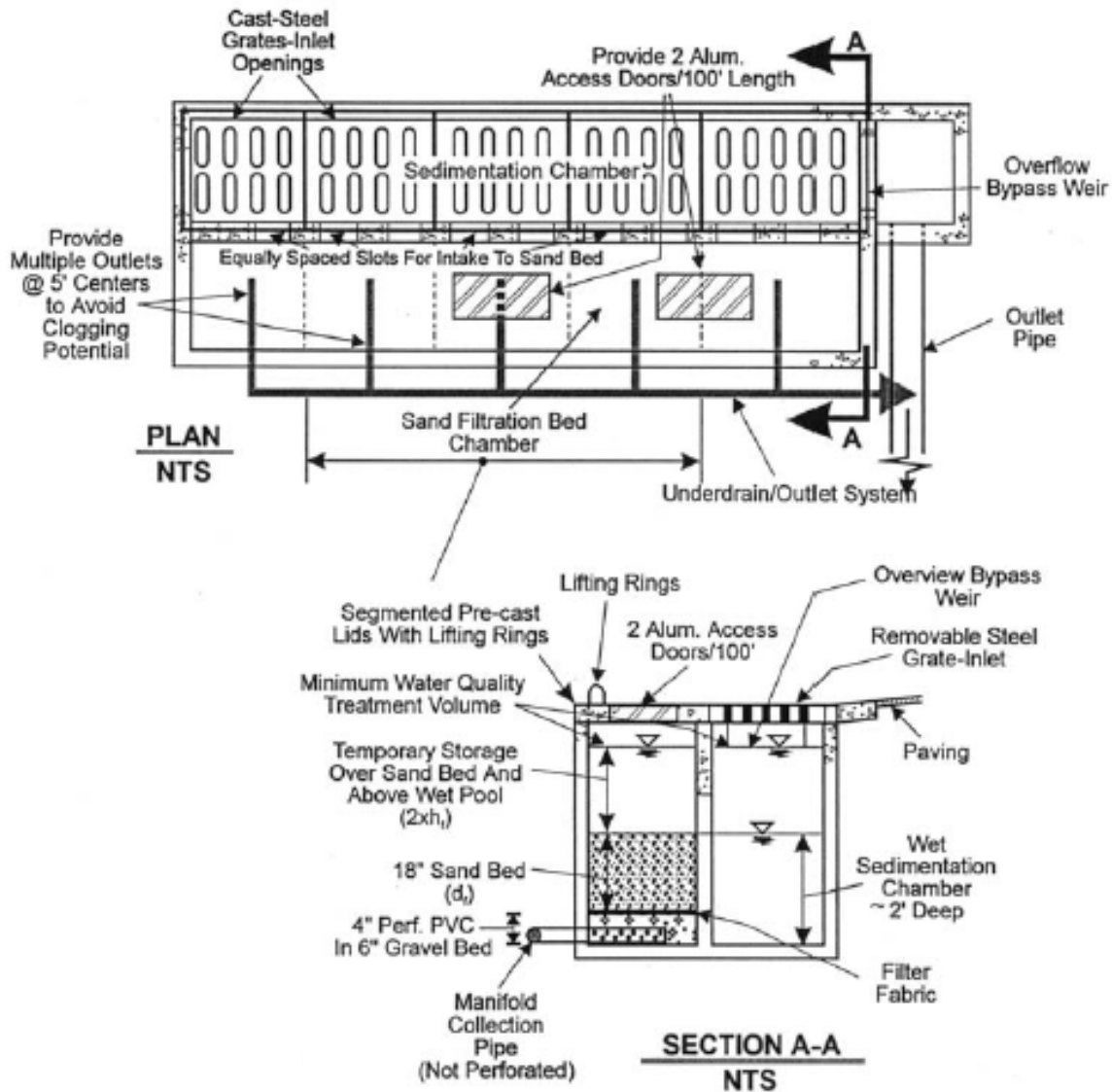

Source: Adapted from Claytor & Schueler, CWP, 1996

C. Outlet structures

Outlet pipe is to be provided from the underdrain system to the facility discharge. Due to the slow rate of filtration, outlet protection is generally unnecessary (except for auxiliary overflows and spillways).

D. Auxiliary spillway

An auxiliary or bypass spillway is included in the surface sand filter to safely pass flows that exceed the design storm flows. The spillway prevents filter water levels from overtopping the embankment and causing structural damage. The auxiliary spillway should be located so that downstream buildings and structures will not be impacted by spillway discharges.

E. Maintenance access

Adequate access must be provided for all sand filter systems for inspection and maintenance, including the appropriate equipment and vehicles. Access grates to the filter bed need to be included in a perimeter sand filter design. Facility designs must enable maintenance personnel to easily replace upper layers of the filter media.

F. Safety features

Surface sand filter facilities can be fenced to prevent access. Inlet and access grates to perimeter sand filters may be locked.

G. Landscaping

Surface sand filters can be designed with a vegetated cover to aid in pollutant removal and to reduce clogging. The vegetation should be capable of withstanding frequent periods of inundation and drought.

H. Additional site-specific design criteria and considerations

1. **Physiographic factors.** Local terrain design constraints:
 - a. **Low relief.** Use of surface sand filter may be limited by low head.
 - b. **High relief.** Filter bed surface must be level.
 - c. **Karst.** Use poly-liner or impermeable membrane to seal bottom of earthen surface sand filter or use watertight structure.
2. **Soils.** No restrictions.
3. **Special downstream watershed considerations.**
 - a. **Coldwater fishery stream.** Evaluate for stream warming; use shorter drain time (24 hours).
 - b. **Aquifer protection.** Use poly-liner or impermeable membrane to seal bottom of earthen surface sand filter or use watertight structure; no exfiltration of filter runoff into groundwater.

I. Design procedures

1. **Step 1.** Compute runoff control volumes from the unified stormwater sizing criteria.
 - a. Calculate the water quality volume (WQv), channel protection volume (Cpv), overbank flood protection volume (Qp), and the extreme flood volume (Qf).
 - b. Details on the unified stormwater sizing criteria and hydrologic calculations are found in Parts 2B and 2C.
2. **Step 2.** Determine if the development site and conditions are appropriate for the use of a surface or perimeter sand filter. Consider the Application and Feasibility criteria in Section 2F-1.

3. **Step 3.** Confirm local design criteria and applicability.
 - a. Consider any special site-specific design conditions/criteria. (See Section 2F-1).
 - b. Check with local jurisdiction officials or other agencies to determine if there are any additional restrictions and/or surface water or watershed requirements that may apply.
4. **Step 4.** Compute WQv peak discharge (Q_{wQ}). (See Section 2C-7). The peak rate of discharge for water quality design storm is needed for sizing of off-line diversion structures (see Section 2C-7).
 - a. Using WQv, compute CN.
 - b. Compute time of concentration using NRCS WinTR-55 method.
 - c. Determine appropriate unit peak discharge from time of concentration.
 - d. Compute Q_{wQ} from unit peak discharge, drainage area, and WQv.
5. **Step 5.** Size flow diversion structure, if needed.
 - a. A flow regulator (or flow splitter diversion structure) should be supplied to divert the WQv to the sand filter facility.
 - b. Size low flow orifice, weir, or other device to pass Q_{wq} . (See Table 1).
6. **Step 6.** Size filtration basin chamber.
 - a. The filter area is sized using the following equation (based on Darcy's Law):

$$A_f = (WQv) (d_f) / [(k) (h_f + d_f) (t_f)] \qquad \text{Equation 1}$$

Where:

A_f = surface area of filter bed (ft²)

d_f = filter bed depth (typically 18-in, no more than 24-in)

k = coefficient of permeability of filter media (ft/day); use 2-3.5 ft/day for sand

h_f = average height of water above filter bed (ft); ($\frac{1}{2} h_{max}$; varies based on site; h_{max} is typically ≤ 6 ft)

t_f = design filter bed drain time (days); (1.67 days or 40 hrs is recommended maximum)

- b. The “k” values for sand were computed by the City of Austin staff based on field observation and actual performance of previously installed sand filters. The values ranged from approximately 0.5-2.7 ft/day, with an average value of 1.5 ft/day. These values are substantially lower than those quoted in textbooks (Hwang, 1981), but allow for clogging associated with accumulated sediments. With an appropriately-sized sedimentation basin (as described above), a value of $k = 2-3.5$ ft/day is recommended (City of Austin, TX, 1988). See Table 2 for “k” values for alternative media.

Table 2: Coefficient of permeability values for stormwater filter media

Filter Media	Coefficient of Permeability (k, ft/day)
Sand	3.5
Peat/sand	2.75
Compost	8.7

Source: Claytor and Schueler, CRC, 1996)

- c. Set preliminary dimensions of filtration basin chamber.
- d. See Section 2F-1 and SUDAS Specifications manual Section 9040 for filter media criteria.

7. **Step 7.** Size sedimentation chamber.

a. **Surface sand filter.**

- 1) The sedimentation chamber is sized to at least 25% of the computed WQv and has a length-to-width ratio of at least 2:1.
- 2) Inlet and outlet structures should be located at opposite ends of the chamber.
- 3) The Camp-Hazen equation is used to compute the required surface area:

$$A_s = - (Q_o/v_p) \times \ln (1-E) \tag{Equation 2}$$

Where:

- A_s = sedimentation surface area (ft²)
- Q_o = rate of outflow = capture volume release over a 24-h period
- v_p = particle settling velocity (ft/sec)
- E = trap efficiency

Assuming:

- 90% trap efficiency
- particle settling velocity (fps) = 0.0033 fps for imperviousness < 75%
- particle settling velocity (fps) = 0.0004 fps for imperviousness ≥ 75%
- average of 24-hour holding period

Then:

- A_s = (0.066) x (WQv) ft² for I < 75% **Equation 3**
- A_s = (0.0081) x (WQv) ft² for I ≥ 75% **Equation 4**
- (I = imperviousness)

- 4) Removal of discrete particles by gravity settling is primarily a function of surface loading (the rate of outflow divided by the basin surface area) and is independent of basin depth. A minimum basin depth of 3 feet is recommended to minimize particle re-suspension and turbulence effects. Therefore, surface area is the primary design parameter for sedimentation affecting removal efficiency (E). E is also a function of particle size distribution. Silt-sized particles are used as the target particle size for sedimentation basin design (i.e., < 20 microns).
- 5) For sites with imperviousness > 75%, which have a higher percentage of coarse-grained sediments (Shaver and Baldwin, 1991), the target capture particle is approximately 40 microns.
- 6) Set preliminary dimensions of sedimentation chamber.

- b. **Perimeter sand filter.** The sedimentation chamber should be sized to at least 50% of the computed WQv. Use same approach as for surface sand filter.

8. **Step 8.** Compute the minimum filter volume, V_{min} .

- a. Typical design for filtration and infiltration practices is to capture and retain the WQv. However, for sand media filters, where pervious areas are intentionally limited, the runoff for the WQv can be a sizable quantity, and complete storage is often not feasible or is cost-prohibitive. Therefore, although the WQv is used to size minimum surface areas for both the sedimentation and filter bed chambers, a volume of three-quarters of the WQv is maintained as the minimum storage volume required.
- b. Storing three-quarters of the WQv versus 100% of WQv is justified since the sedimentation chamber is continually draining into the filter bed during the course of a storm event. Only short duration, high intensity storms are likely to exceed the three quarters WQv threshold.

$$V_{min} = 0.75 \times WQv \quad \text{Equation 5}$$

9. **Step 9.** Compute storage volumes within the entire facility and determine sedimentation chamber orifice size.

- a. **Surface sand filter.** The overall design is based on fitting the structure to the existing site and remaining within the sizing limits. Based on past experience, 75% of the WQv must fit within the three basic compartments in the sand filter: sedimentation chamber, head above the sand bed, and saturated pore spaces within the sand bed as indicated below:

$$V_{min} = 0.75WQv = V_s + V_f + V_{f-temp} \quad \text{Equation 6}$$

- 1) Compute V_f = water volume within filter bed/gravel /pipe = $A_f \times d_f \times n$ (n =porosity = 0.4 for most applications).
 - 2) Compute V_{f-temp} = temporary storage volume above the filter bed = $2 \times h_f \times A_f$
 - 3) Compute V_s = volume within the sedimentation chamber = $V_{min} - V_f - V_{f-temp}$
 - 4) Compute h_s = height in sedimentation chamber = V_s / A_s
 - 5) Check that h_s and h_f match with the available head at the site and other dimensions fit – adjust as necessary in design iterations until all dimensions fit the available space.
 - 6) Size orifice from sediment chamber to filter chamber to release V_s within 24 hours at average release rate with $0.5 h_s$ as average head.
 - 7) Design outlet structure with perforations allowing for a safety factor of 10.
 - 8) Size distribution chamber to spread flow over filtration media – level spreader weir or orifices.
- b. **Perimeter sand filter.** Computation for the perimeter sand filter generally follows the procedure for the surface sand filter; the volume calculations change as noted below:
 - 1) Compute V_f = water volume within filter bed/gravel /pipe = $A_f \times d_f \times n$ (n =porosity = 0.4 for most applications).
 - 2) Compute V_w = wet pool storage volume = $A_s \times 2$ -ft minimum
 - 3) Compute V_{temp} = temporary storage volume = $V_{min} - (V_f + V_w)$
 - 4) Compute h_{temp} = temporary storage height = $V_{temp} / (A_f + A_s)$
 - 5) Check $h_{temp} \geq 2 \times h_f$; otherwise, decrease h_f and re-compute; check dimensions against available head and area and change as required in design iterations until all site dimension fit.

- 6) Size distribution slots from sediment chamber to filter chamber using the orifice equation.
10. **Step 10.** Design inlets, pre-treatment facilities, underdrain system, and outlet structures.
- a. **Surface Sand Filter.**
 - 1) Dry detention basin.
 - 2) Minimum volume = $0.75 \times WQ_v$: split between volume within filter bed (voids), volume above filter bed, and volume within pre-treatment chamber.
 - 3) Perforated standpipe with orifice sized to release volume (within sedimentation basin) over 24-hour duration (Figure 6. Note: The size and number of perforations depends on the release rate needed to achieve 24-hour detention.
 - 4) Overflow weir within the sedimentation chamber is set at design treatment volume, sized to pass $2/3$ of WQ_v peak flow. Overflow weir within sand bed chamber set at design treatment volume, sized to pass $1/3$ of WQ_v peak flow. This ensures at least partial treatment for flows exceeding $0.75 \times WQ_v$.
 - 5) Permanent sediment trap: Since the sedimentation basin is dry, a permanent sediment trap is recommended. This consists of a small storage area to trap incoming sediment and remove this from the basin flow regime. It is recommended that the sediment trap volume be equal to 10% of the sedimentation basin volume. Water collected in the trap is conveyed directly to the flow distribution vault (Figure 6).
 - b. **Perimeter sand filter.**
 - 1) Wet retention basin.
 - 2) Wet volume (V_w) = $A_s \times$ depth; (2' minimum depth permanent pool storage).
 - 3) Total minimum volume = $0.75 \times WQ_v$: Split between volume within filter bed (voids), wet volume within sedimentation chamber, volume above wet volume, and volume above sand bed.
 - 4) Elevation of overflow weir to outlet chamber set at top of dry storage elevation ($0.75 \times WQ_v$), sized to pass 100% of incoming 10 year design flow.

Figure 6: Sediment trap configuration

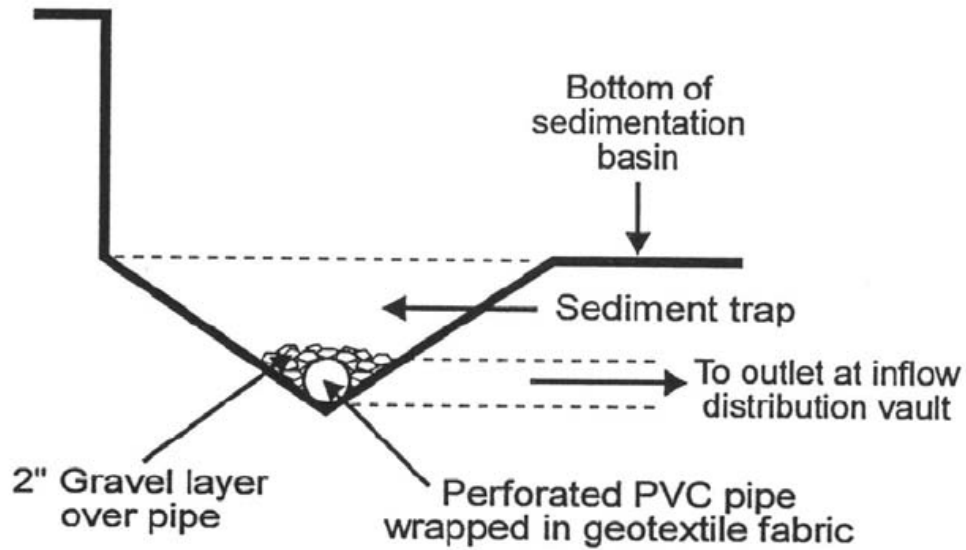

Source: Adapted from Claytor and Schueler, CWP, 1996

11. **Step 11.** Compute overflow weir sizes.

a. **Surface sand filter.**

- 1) Size overflow weir at elevation h_s in sedimentation chamber (above perforated stand pipe) to handle surcharge of flow through filter system from 25-year storm (see example).
- 2) Plan inlet protection for overflow from sedimentation chamber and size overflow weir at elevation h_f in filtration chamber (above perforated stand pipe) to handle surcharge of flow through filter system from 25-year storm (see example).

b. **Perimeter sand filter.** Size overflow weir at end of sedimentation chamber to handle excess inflow, set at WQ_v elevation.

J. Inspection and maintenance requirements

Table 3: Typical maintenance activities for sand filters

Maintenance Activity	Schedule
Ensure that contributing area, facility, inlets and outlets are clear of debris.	Monthly
Ensure that the contributing area is stabilized and mown, with clippings removed.	
Remove trash and debris.	
Ensure that the filter surface is not clogging (also check after significant storms).	
Minimize oil/grease/sediment entry to system.	
If permanent water level (perimeter sand filter), ensure against leaks.	
Ensure sediment chamber <50% full/sediment depth <6", or remove sediment.	Annually
Ensure drainage time <48 hours, or remove & replace top layers of filter media.	
Ensure no cracking or deterioration of concrete.	
Ensure no cracking or deterioration of concrete.	
Inspect grates (perimeter sand filter).	
Inspect grates (perimeter sand filter).	
Inspect inlets, outlets and overflow spillway to ensure good condition.	
Repair or replace any damaged structural parts.	
Stabilize any eroded areas.	
Ensure that flow is not bypassing the facility.	
Ensure no noticeable odors detected outside facility.	
Rake surface of filter bed.	As needed
Replace clogged filter fabric.	

Source: WMI, 1997; Pitt, 1997

1. A record should be kept of the dewatering time for a sand filter to determine if maintenance is necessary.
2. When the filtering capacity of the sand filter facility diminishes substantially (i.e., when water ponds on the surface of the filter bed for more than 48 hours), then the top layers of the filter media (topsoil and 2-3 inches of sand) will need to be removed and replaced. This will typically need to be done every 3-5 years for low sediment applications, more often for areas of high sediment yield or high oil and grease.
3. Removed sediment and media usually disposed of in a landfill.
4. Regular inspection and maintenance is critical to the operation of the sand filters. Responsibility for maintenance of the sand filter system must be assigned to a responsible authority through a legally binding and enforceable maintenance agreement. The maintenance agreement is executed as a condition of plan approval.

Table 4: Design procedures – sand filters

Preliminary Hydrologic Calculations					
1a	Compute WQv requirements				
	Design rainfall	P=		inches	
	Total drainage area for site	A _T =		acre	
	Impervious area	A _{impa} =		acre	
	% impervious area	Imp=		%	
	Compute runoff coefficient: $R_v = 0.05 + [0.009 * (\text{Imp}\%)]$	R _v =			
	Compute WQv ($WQ_v = [R_v * P * A] / 12$)	WQ _v =		acre-ft	ft ³
1b	Compute CPv				
	Compute average release rate: 24-hr duration	Q _{avg} =		ft ³ /s	
	Compute Q _{p-25}	Q _{p-25} =		ft ³ /s	
Sand Filter Design					
2	Is the use of sand filter appropriate?		Low point in development area=		ft
			Low point at stream invert=		ft
			Total available head=		ft
			Average depth, h _f =		ft
3	Confirm local design criteria and applicability				
4	Compute WQv peak discharge (Q _{WQ}): WINTR-55		See Section 2C-7		
	Compute curve number (CN)		CN=		
	Compute time of concentration (T _c)		T _c =	hours	
	Compute Q _{WQ}		Q _{WQ} =	ft ³ /s	
5	Size flow diversion structure		A=	ft ²	
	Low-flow orifice – orifice equation		diameter=	inches	
	Overflow weir – weir equation		length=	ft	
6	Size filtration bed chamber				
	Compute area from Darcy’s Law		A _f =	ft ²	
	Using length-to-width ratio (2:1)		length=	ft	
7	Size sedimentation chamber				
	Compute area from Camp-Hazen equation		A _s =	ft ²	
	Using W from Step 5, compute length		length=	ft	
8	Compute V _{min}		V _{min} =	ft ³	
9	Compute filter component volumes				
	<i>Surface Sand Filter</i>				
	Volume within filter bed		V _f =	ft ³	
	Temporary storage above filter bed		V _{f-temp} =	ft ³	
	Sedimentation chamber (remaining volume)		V _s =	ft ³	
	Height in sedimentation chamber		h _s =	ft	
	Perforated standpipe – orifice equation		A=	ft ²	
	<i>Perimeter Sand Filter</i>				
	Compute volume in filter bed		V _f =	ft ³	
	Compute wet pool storage		V _w =	ft ³	
	Compute temporary storage		V _{temp} =	ft ³	
			h _{temp} =	ft	
10	Compute overflow weir sizes				
	Compute overflow – orifice equation		Q=	ft ³ /s	
	Weir length from sedimentation basin – weir equation		length=	ft	
	Weir length from filtration chamber – weir equation		length=	ft	

- 5) Pervious areas (silty soils): $R_v = 0.13$
- c. Weighted $R_v = [(0.90)(.98) + (0.04)(.74) + (0.38)(.86) + (0.02)(1.0) + (0.86)(.13)] / 2.2$
- $$R_v = (0.88 + .03 + 0.33 + 0.02 + 0.11) / 2.2 = 0.63$$
- $$WQ_v = R_v \times P = 0.63 \times 1.25\text{-in} = 0.78 \text{ inches}$$
- $$WQ_v = 0.78\text{-in} \times 2.2 \text{ ac} \times 1/12 = .14 \text{ acre-ft}$$
- $$WQ_v = .14 \text{ ac-ft} \times 43,560 \text{ ft}^2/\text{ac} = 6,098 \text{ ft}^3$$
- d. Compute maximum head available (see site elevation sketch – Figure 8)
- 1) Low point in street = Elev 46.5 (subtract 2 feet to pass Q_{10} discharge) = Elev. 44.5
 - 2) Invert @ storm drain system = Elev. 36.5
 - 3) Invert out of filter bed = Elev. 37.0
 - 4) Top of filter bed = Elev. 39.3
 - 5) Allowable depth ($2 \times h_f$) = $44.5 - 39.3 = 5.2 \text{ ft}$, use $2 \times h_f = 5 \text{ ft}$

Figure 8: Bucketsville distribution center site profile

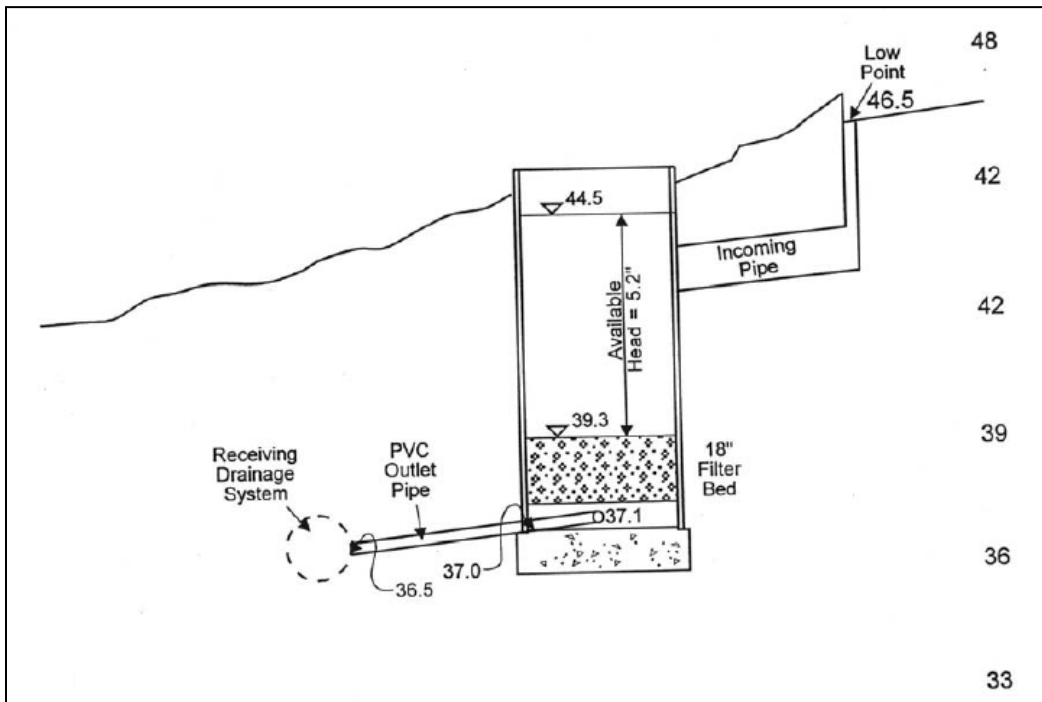

3. **Compute WQv Peak Discharge (Q_{WQ}).** From Section 2C-7 and Modified NRCS WINTR55 procedure.
- a. $CN = 1000 / [10 + 5P + 10Q_a - 10(Q_a^2 + 1.25Q_aP)^{0.5}]$
 $P =$ rainfall depth for water quality storm – 1.25 inches
 $Q_a =$ runoff volume, inches (equal to $P \times R_v$)
 - b. $CN = 1000 / [10 + 5(1.25'') + 10(.78'') - 10[(.78'')^2 + 1.25(.78'')(1.25'')]^{0.5}]$

- c. $CN = 94.94$ Use $CN = 95$
- d. Use $t_c = 0.1$ hour
- e. Compute Q_{wQ} using WINTR-55 using modified CN and t_c :
 WINTR55 results for *modified* $CN = 95$ and $t_c = 0.1$ hr:
 For 1.25-inch rainfall, $q_u = 768$ csm/in
 $Q_{wQ} = 2.64$ ft³/sec
- f. Compute 1-yr, 2-yr, and 10-yr peak discharge using conventional WINTR55 procedure:
 - 1) For 61% impervious, B soils, $CN=98$ for Imp and $CN=61$ for open space
 - 2) $CN = 84$
 - 3) Use $t_c = 0.1$ hr
 - 4) WINTR55 results:

Design Storm Event	Runoff Volume (inches)	Peak discharge, Q (cfs)	Unit discharge, q_u (csm/in)
1-yr	0.943	3.45	1002.51
2-yr	1.426	4.89	1422.78
10-yr	2.590	8.82	2563.12

4. **Size flow diversion structure (see Figure 9).**

- a. Size low-flow pipe to pass Q_{wQ} of 2.64 ft³/sec with 1.5 feet of head
 - 1) $Q = C * A * (2gh)^{0.5}$
 - 2) $2.64 \text{ ft}^3/\text{sec} = 0.6 * A * [2(62.2 \text{ ft}/\text{sec}^2)(1.5 \text{ ft})^{0.5}$
 - 3) $A = 0.322 \text{ ft}^2 = 0.785 d^2$ (d = diameter)
 - 4) $d = 0.64 \text{ ft} = 7.68 \text{ in}$ Use 8-inch diameter pipe
- b. 10-year overflow elevation = 44.3 feet
- c. Set low-flow orifice invert elevation @ $44.3 - [1.5 + ((0.5 * 8'')(1/12 \text{ ft}/\text{in}))] = 42.47 \text{ ft}$
- d. Set low-flow orifice invert elevation @ 42.5 feet
- e. Compute overflow elevation in diversion structure (weir equation)
 - 1) 10-year peak flow = 8.82 cfs
 - 2) $Q = C * L * h^{3/2}$
 - 3) $8.82 \text{ cfs} = 3.1 * 5.0 \text{ ft} * h^{3/2}$
 - 4) $h = 0.69 \text{ ft}$
 - 5) Overflow elevation = $44.3 + 0.69 = 45 \text{ ft}$
- f. Size outlet pipe with 2 feet of head
 - 1) $Q = C * A * (2gh)^{0.5}$
 - 2) $8.82 \text{ cfs} = 0.6 * A * [2(62.2 \text{ ft}/\text{sec}^2)(2 \text{ ft})^{0.5}$
 - 3) $A = 0.932 \text{ ft}^2 = 0.785d^2$
 - 4) $D = 1.09 \text{ ft} = 13.08 \text{ inches}$ Use 15-inch RCP outlet pipe
 - 5) Set invert @ Elev. $44.9 - [2 \text{ ft} + ((0.5 * 15'')(1/12 \text{ ft}/\text{in}))] = 42.27 \text{ ft}$ Use 42.3 ft

Figure 9: Flow diversion structure

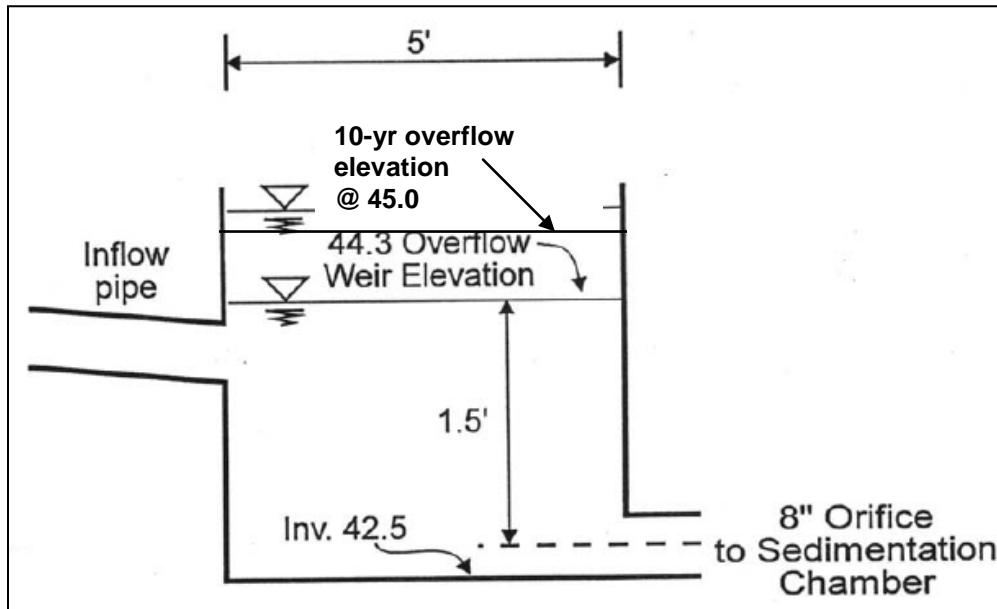

5. **Size sand filter bed.**

a. $A_f = (WQv) (d_f) / [(k) (h_f + d_f) (t_f)]$

Equation 7

b. $A_f = (6,098 \text{ ft}^3) (1.5\text{-ft}) / [(3.5 \text{ ft/d}) (2.5\text{-ft} + 1.5\text{-ft}) (40\text{-hr}/24\text{hr/d})]$

c. $A_f = 393 \text{ ft}^2 = 16 \text{ ft} \times 24.5 \text{ ft}$ Use $16 \text{ ft} \times 26 \text{ ft} = 416 \text{ ft}^2$

Where: $d_f = 1.5 \text{ ft}$

$h_f = 2.5 \text{ ft}$

$k = 3.5 \text{ ft/day}$ (See Table 2)

$t = 40 \text{ hours}$

6. **Size the sedimentation chamber.**

Use Camp-Hazen Equation (for $I < 75\%$) :

$A_s = (0.066/\text{ft} \times (WQv) \text{ ft}^2$

Equation 8

$A_s = (0.066/\text{ft}) \times (6,098 \text{ ft}^3) = 402 \text{ ft}^2$

For 16-foot width, $402 \text{ ft}^2 / 16\text{-ft} = 25.12 \text{ ft}$ Use $16 \text{ ft} \times 26 \text{ ft} (416 \text{ ft}^2)$

7. **Compute $V_{\min} = 0.75 \times WQv$.**

Equation 9

$V_{\min} = 0.75 \times (6,098 \text{ ft}^3) = 4,574 \text{ ft}^3$

8. **Compute individual component volumes within the filtration structure.**

- a. Compute volume within the filter bed (V_f): $V_f = A_f \times d_f \times n$

$$V_f = 416 \text{ ft}^2 \times 2 \text{ ft} \times 0.4 = 332 \text{ ft}^3$$

- b. Compute temporary storage above the filter bed ($V_{f\text{-temp}}$): $V_{f\text{-temp}} = 2 \times h_f \times A_f$

$$V_{f\text{-temp}} = 2 \times 2.5 \text{ ft} \times 416 \text{ ft}^2 = 2080 \text{ ft}^3$$

- c. Compute remaining volume for sedimentation chamber (V_s): $V_s = V_{\text{min}} - V_f - V_{f\text{-temp}}$

$$V_s = 4,574 \text{ ft}^3 - (332 \text{ ft}^3 + 2080 \text{ ft}^3) = 2,162 \text{ ft}^3$$

- d. Compute height in sedimentation chamber (h_s): $h_s = V_s / A_s$

$$h_s = 2,162 \text{ ft}^3 / 402 \text{ ft}^2 = 5.38 \text{ ft}$$

5.38 ft > available head of 5.2 ft

Increase length of sedimentation chamber to 28 ft: $A_s = 16 \text{ ft} \times 28 \text{ ft} = 448 \text{ ft}^2$

$$h_s = 2,162 \text{ ft}^3 / 448 \text{ ft}^2 = 4.82 \text{ ft} \qquad \text{Use } h_s = 5.0 \text{ ft}$$

$$h_s = 5.0 \text{ ft} \text{ (} h_s > 2 \times h_f \text{ and } h_s > 3 \text{ ft)}$$

5.0 ft is less than available head of 5.2 ft OK

9. Compute overflow weir sizes.

- a. From sedimentation chamber (size to pass 2/3 of WQv peak discharge)

$$Q_w = C \times L \times h^{3/2}$$

$$0.67 \times 2.64 \text{ cfs} = 3.1 \times L \times (1 \text{ ft})^{3/2} \quad L = 0.57 \text{ ft} \quad \text{Use } L = 0.6 \text{ ft}$$

- b. From filter bed chamber (size to pass 1/3 of WQv peak discharge)

$$Q_w = C \times L \times h^{3/2}$$

$$0.33 \times 2.64 \text{ cfs} = 3.1 \times L \times (0.2 \text{ ft})^{3/2} \quad L = 3.14 \text{ ft} \quad \text{Use } L = 3.2 \text{ ft}$$

Figure 10: Plan and profile of surface sand filter design example

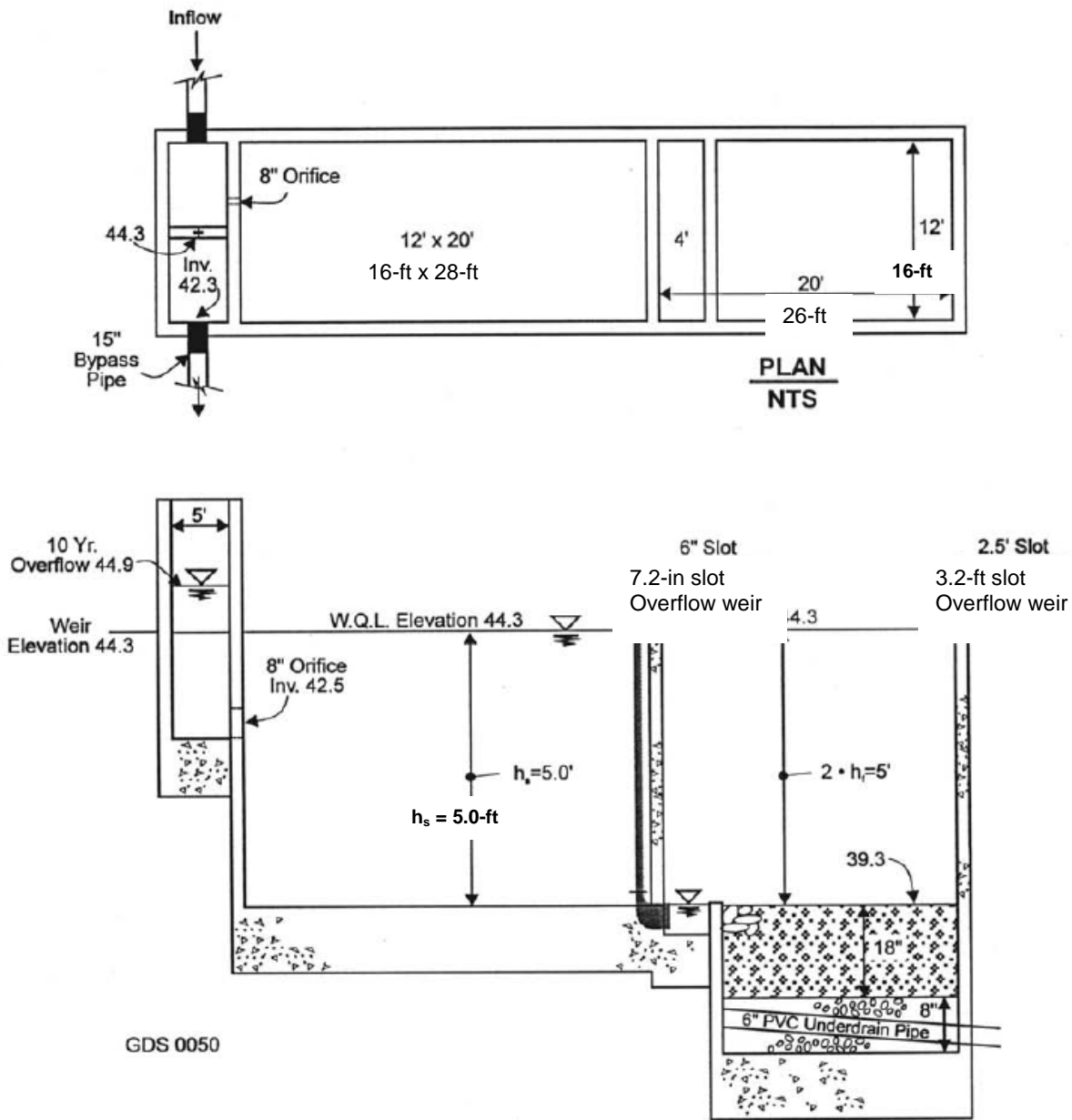

2F-3 Underground Sand Filter



BENEFITS			
Low = <30% Medium = 30-65% High = 65-100%			
	Low	Med	High
Suspended Solids			■
Nitrogen	■		
Phosphorous		■	
Metals		■	
Bacteriological		■	
Hydrocarbons		■	

Description: Multi-chamber structure designed to treat stormwater runoff through filtration, using a sediment forebay and a sand bed as its primary filter media. In some cases, a third chamber collects filtered runoff. Typically, an underdrain is used to return the filtered runoff to the conveyance system.

Typical Uses: High density/ultra-urban location where available land is restricted, such as a receiving area for runoff from an impervious site.

Advantages/benefits:

- Stormwater filters have their greatest applicability for small development sites – drainage areas of up to 5 surface acres.
- Good for highly impervious areas; good retrofit capability – good for areas with extremely limited space.
- Can provide runoff quality control, especially for smaller storms; generally provide reliable rates of pollutant removal through careful design and regular maintenance.
- High removal rates for sediment, BOD, and fecal coliform bacteria.
- Precast concrete shells available, which decreases construction costs.
- No restrictions on soils at installation site, if filtered runoff is returned to the conveyance system.

Disadvantages/limitations:

- Intended for space-limited applications.
- High maintenance requirements.
- Not recommended for areas with high sediment content in stormwater, or areas receiving significant clay/silt runoff.
- Relatively costly.
- Possible odor problems.
- Porous soil required at site, if filtered runoff is to be exfiltrated back into the soil.
- Not recommended for residential developments due to higher maintenance burden.

Maintenance requirements

- Inspect for clogging – rake first inch of sand.
- Remove sediment from forebay/chamber.

A. Description

The underground sand filter is a design variant of the sand filter located in an underground vault designed for high-density land use or ultra-urban applications where there is not enough space for a surface sand filter or other structural stormwater control. It is intended primarily for extremely space-limited and high-density areas. In this design, the sand filter is placed in a three-chamber underground vault accessible by manholes or grate openings (Figure 2). The vault can be either on-line or off-line in the storm drain system. Of the three chambers, the initial chamber is a sedimentation (pre-treatment) chamber that temporarily stores runoff and utilizes a wet pool to capture sediment. The sedimentation chamber is connected to the sand filter chamber by a submerged wall that protects the filter bed from oil and debris. The filter bed is 18-24 inches deep, and may have a protective screen of gravel or permeable geotextile to limit clogging. During a storm, the water quality volume (WQv) is temporarily stored in both the first and second chambers. Flows in excess of the filter's capacity are diverted through an overflow weir. The sand filter chamber also includes an underdrain system with inspection and cleanout wells. Perforated drain piping under the sand filter bed extends into a third chamber that collects filtered runoff. Flows beyond the filter capacity are diverted through an overflow weir.

Due to its location below the surface, underground sand filters have a high maintenance burden and should only be used where adequate inspection and maintenance can be ensured. For this reason, the underground is considered a limited-application structural BMP.

B. Pollutant removal capabilities

Underground sand filter pollutant removal rates are similar to those for surface and perimeter sand filters (see Section 2F-1).

C. Design criteria

1. Underground sand filters are typically used on highly impervious sites of 1 acre or less. The maximum drainage area that should be treated by an underground sand filter is 5 acres.
2. Maintain a minimum of 2-foot separation from seasonal high groundwater level and the bottom of the filter.
3. Use a three-chamber system as shown in Figures 1, 2, and 3.
4. Initial chamber serves as sedimentation (pre-treatment) to temporarily store runoff and utilizes a wet pool to capture sediment. One foot of sediment storage is recommended.
5. Underground filter components:
 - Wet retention basin
 - Wet volume: $(V_w) = A_s \times \text{depth}$ (3 feet deep, minimum permanent pool storage)
 - Total minimum volume: $V_{\min} = 0.75 \times \text{WQv}$
 - V_{\min} split between volume within filter bed (voids), wet volume within sedimentation chamber, volume above wet volume, and volume above sand bed.
6. Overflow weir elevation (in filter chamber) set at design treatment volume, sized to pass 2/3 of WQv peak flow.

7. Flows above the filter capacity are diverted through an overflow weir.
8. Consult the design criteria for the perimeter sand filter (see Section 2F-2) for the rest of the underground filter sizing and design steps.

Figure 1: Underground sand filter volumes

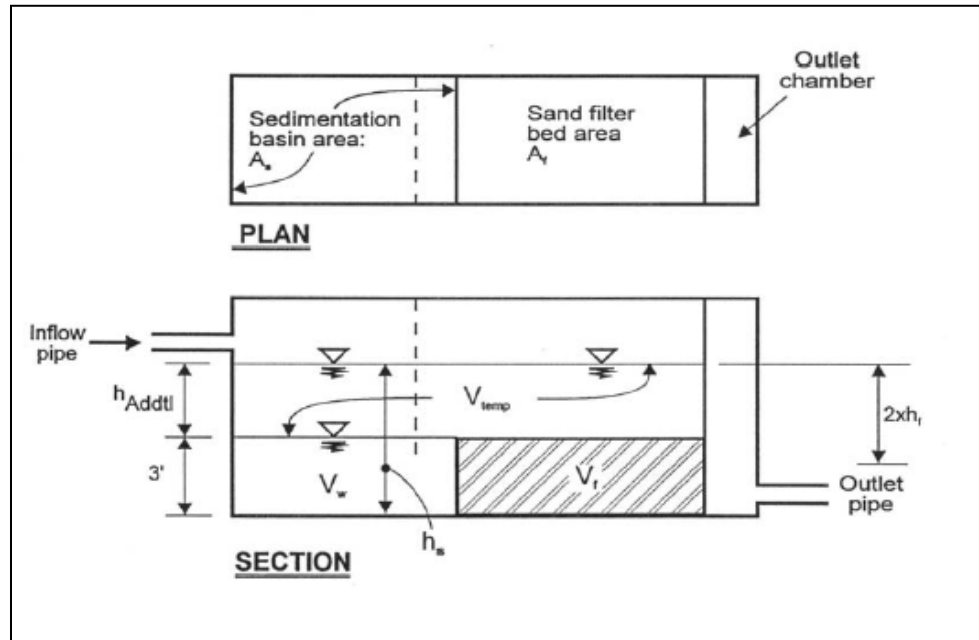

Source: Claytor and Schueler, 1996

9. Sedimentation chamber connected to the sand filter by a submerged wall that protects the filter bed from oil and debris. It should extend 1 foot above and below the design flow water level, and be spaced a minimum of 5 feet horizontally from the inlet. In the event of plugging, provide for bypass of flows. Access must be provided to both sides of the baffle.
10. A maximum of 6 inches between the top of the flow spreader and the top of the sand bed is recommended to reduce sand disturbance. A flow spreader or pipe and manifold system (minimum pipe diameter of 8 inches) can be used.
11. Filter bed is typically 18-24 inches deep; may have a protective screen of gravel or permeable geotextile on top to limit clogging (King County, 1998).
12. The sand filter chamber also includes an underdrain system with inspection and cleanout wells. Perforated drainpipes under the sand filter bed extend into a third chamber that collects filtered runoff. Internal diameters of underdrain piping are a minimum of 6 inches and two rows of 1/2-inch holes spaced a maximum of 6 inches apart longitudinally, with rows 120 degrees apart (set with holes downward). Maximum perpendicular separation between feeder pipes is 15 feet. All piping is Schedule-40 PVC or greater wall thickness.
13. Drain rock is a clean washed 3/4-inch to 1.5-inch rock or limestone aggregate (Iowa DOT #3), free of silt and clay fines and organic material.
14. To prevent anoxic conditions, a minimum of 24 ft² of ventilation grate is provided for each 250 ft² of sand bed area.

15. The underground vault should be tested for water tightness prior to placement of filter layers.
16. Underground sand filters are typically constructed on-line, but can be constructed off-line. For off-line construction, the overflow between the second and third chambers is not included.
17. Adequate maintenance access must be provided to the sedimentation and filter bed chambers:
 - a. At grade access panels are provided for the entire length of the sand bed.
 - b. A dewatering valve is provided just above the sand bed. To assist with maintenance of the sand filter, an inlet shut-off/bypass valve is provided.
 - c. Cleanout wyes with caps or junction boxes are provided at both ends of the collector pipes. Cleanouts must extend to the surface of the filter. A valve box is provided for access to the cleanouts. Access for cleaning all underdrain piping is provided.

D. Inspection and maintenance requirements

Table 1: Typical maintenance activities for underground sand filters

Maintenance Activity	Schedule
Monitor water level in sand filter chamber	Quarterly and following large storm events
Sedimentation chamber should be cleaned out when the sediment depth reaches 12-inches	As needed
Remove accumulated oil and floatables in sedimentation chamber	As needed (typically every 6 months)

Source: Claytor and Schuler, CRC, 1996

Additional inspection and maintenance requirements for underground filters are similar to those for surface sand filter facilities (Section 2F-2).

Figure 2: Underground sand filter

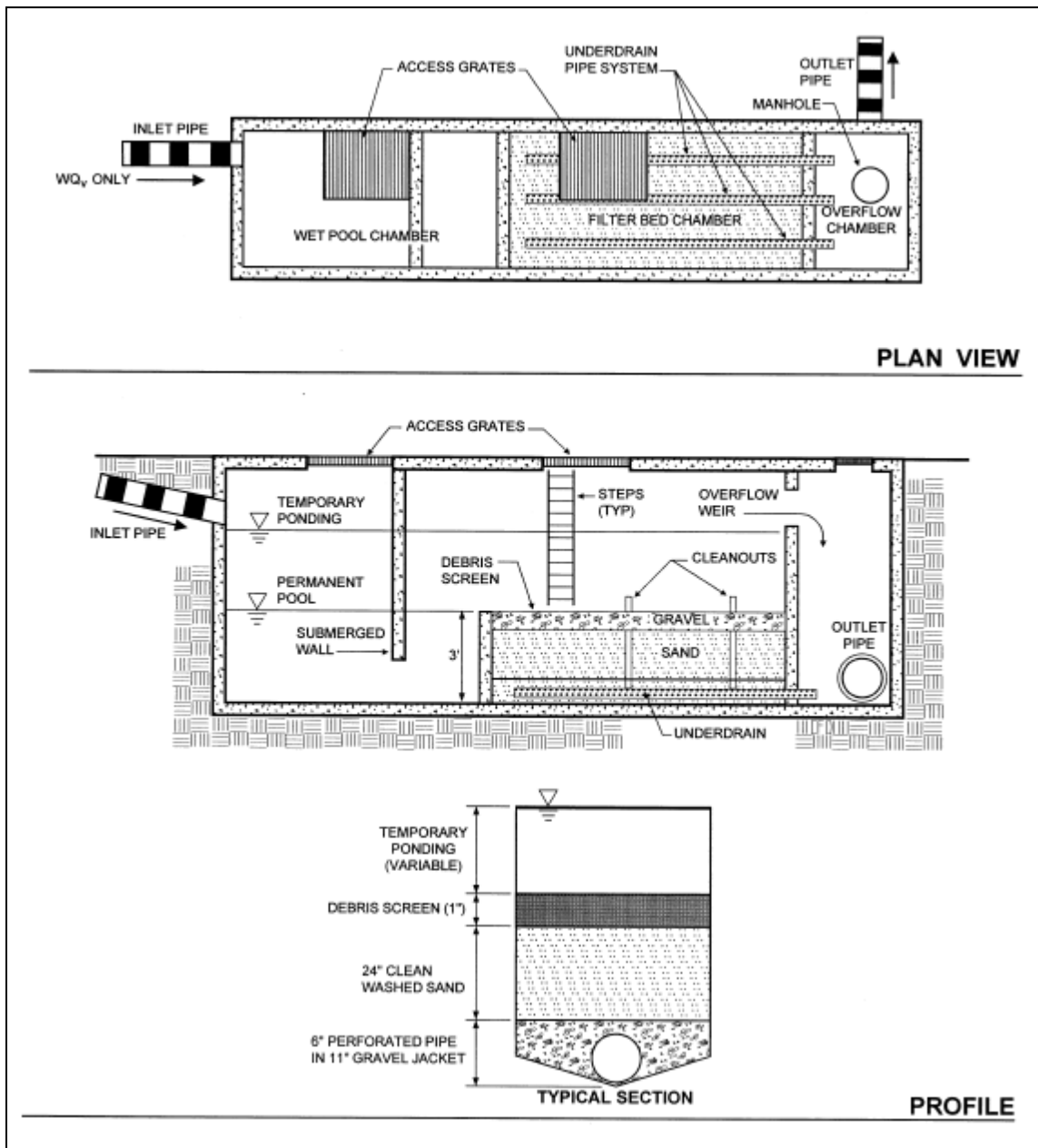

Source: Adapted from Claytor & Schueler, CRC, 1996

Figure 3: Underground sand filter components

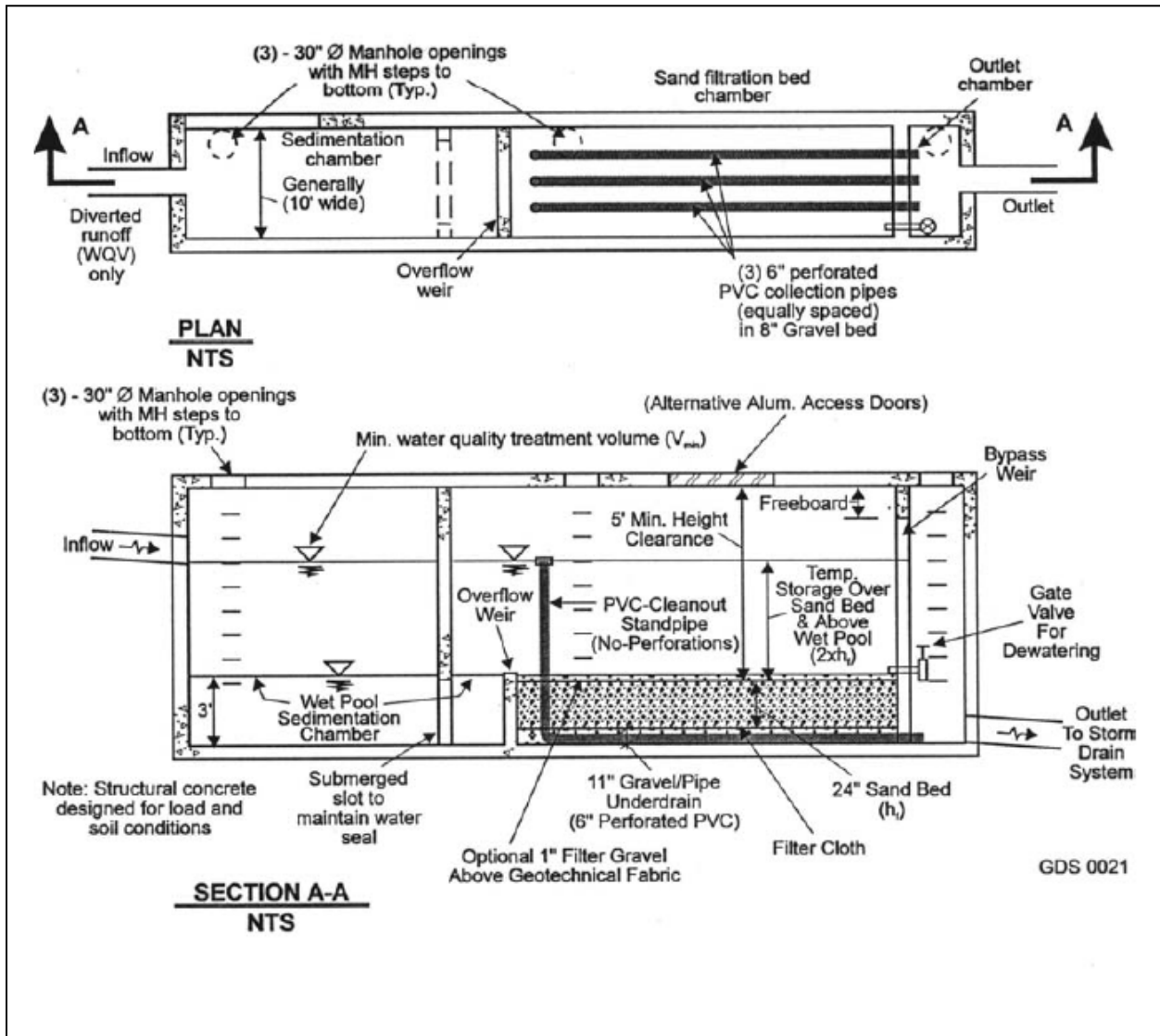

Source: Adapted from Claytor & Schueler, CRC, 1996